



At home,
across the world.

FRAME 80 TO 400

LOW TENSION MACHINES



 **Crompton
Greaves**
EVERYDAY SOLUTIONS



Crompton Greaves Ltd.

Crompton Greaves Ltd., a pioneering leader with more than 67 years of experience and expertise in the management of electric energy, is today India's largest private sector enterprise in electrical engineering. The Company has 28 manufacturing units in India, 19 branch offices in India and many distributors all over the world . Recently Crompton Greaves has acquired Pauwels Group Belgium and their Transformer manufacturing facilities in 5 countries to reckon its position in International market. Today CG is amongst the top 10 manufacturer of transformer in the world. It is also the undisputed leader in India and a recognized manufacturer in International market for many other products including LT Motors.



LT Motors division, for the past six decades has lead the industry in India developing motors that deliver greater performance and reliability while using less electricity. The motors are manufactured at the Crompton Greaves State-of-the-art plant at Ahmednagar, consistently ensuring conformance to International standards for energy conservation and environment preservation.



INDEX

SR. NO.	DESCRIPTION	PAGE NO.
A	Energy Efficient Motors LEVEL2	1
	Performance Data	5
	Outline Dimension Drawings	8
B	TEFC Slipring Motors	13
	Performance Data	13
	Outline Dimension Drawings	15
C	SPDP Slipring Motors	17
	Performance Data	17
	Outline Dimension Drawings	18
D	Energy Efficient Motors LEVEL 1	20
	Performance Data	23
E	Flame Proof Motors	25
	Performance Data	29
	Outline Dimension Drawings	32
F	AC Generators - 5 kVA to 625 kVA	40
	Performance Data	43
	Outline Dimension Drawings	44
G	High Speed Brushless Alternators	46
I	DC Motors	47
	Performance Data	49
	Outline Dimension Drawings	50
J	Aux Mill Duty DC Motors	51

TEFC Motors

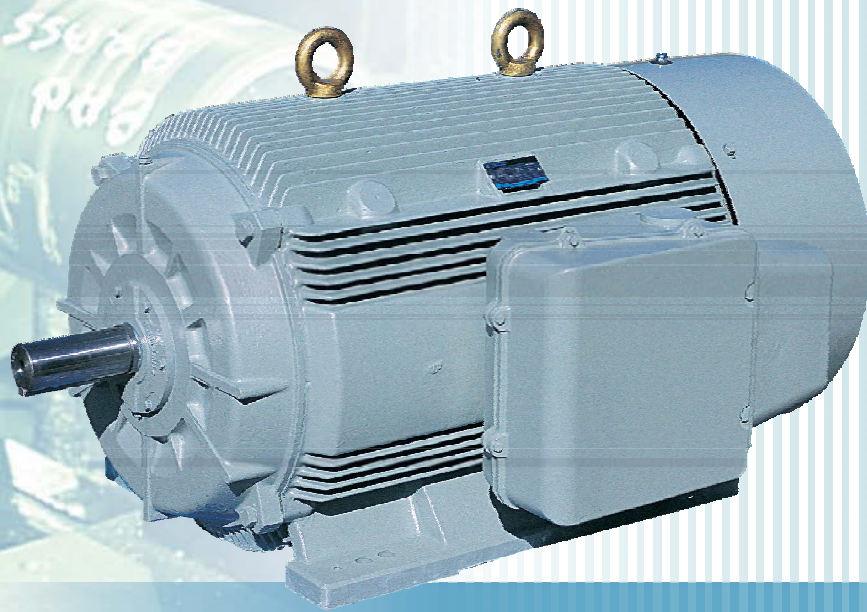

0.18 kW to 450 kW
From 80 to 400 Frame



EFF Level 2

ENERGY EFFICIENT MOTORS LEVEL 2

TEFC CAGE MOTORS

- Energy Efficiency level 2 as per IS:12615
- Energy Efficiency as per CEMEP Standards prevalent in Europe

- Sleek and compact design, Improved aesthetics

- 'V' seal arrangement up to 355 frame - Easier assembly of bearing housing

- Integral bearing cover with endshield up to 225 frame

- Larger terminal box for accommodating bigger Aluminium cables

- Sophisticated CNC Machines, Most Advanced Manufacturing Technology & Test Plant - Improved reliability.

STANDARD SPECIFICATIONS

RANGE	0.18 kW to 400 kW (FRAME 63 to 400) Multi speed options are also available
VOLTAGE	415 V +/- 10 %
FREQUENCY	50 Hz +/- 5 %
COMBINED VARIATION	+/- 10 % (ABSOLUTE SUM)
INSULATION	Class 'F' (Temp. rise limited to class 'B') as standard
MOUNTING	Horizontal foot mounting (B3) as per IS :1231.
AMBIENT / TEMPERATURE RISE	50 ° C / 70 ° C
DEGREE OF PROTECTION	IP55 AS PER IS: 4691



EFF Level 2

BEARINGS & TERMINAL BOX DETAILS

BEARING SIZE CHART

FRAME SIZE	DE BEARING	NDE BEARING
SD63	6201ZZ	6201ZZ
SD71	6203ZZ	6203ZZ
SD/ND80	6204ZZ	6204ZZ
SD/ND90S/L	6205ZZ	6205ZZ
SD100L	6206ZZ	6206ZZ
ND100L	6206ZZ	6205ZZ @
SD/ND112M	6306ZZ	6205ZZ @
ND/NC132 S/M	6308ZZ	6208ZZ
SD132 S/M	6308ZZ	6305ZZ
ND160M/L	6309 2RS	6209 2RS
ND180M	6310 2RS	6310 2RS
ND200L	6312 2RS	6312 2RS
ND225M	6313 2RS	6313 2RS
ND250M - 2P	6314	6314
ND250M 4P UP	6314	6314
ND280S/M 2P	6314	6314
ND280S/M 4P & UP	6318	6318
ND315M/L 2 P	6315	6315
ND315L 4P & UP	6319	6319
ND355S/M/L/LX 2P	6316	6316
ND355S/M/L 4P UP	6321	6321
ND355LX 4P UP	6322	6322
ND400LX 2P	6318	6318
ND400LX 4P UP	NU322	6322

@ For single shaft extension. For double shaft extension-Bearing Size-6206 ZZ.

TERMINAL BOX :

TEFC FRAME	MAXIMUM CABLE SIZE		NO. OF MAIN TERMINALS	TERMINAL STUD SIZE		BSC ENTRY	
	DOL	STAR/DELTA		MAIN	EARTH	NOS.	SIZE
SD63-SD71	4CX4mm ²	-	6	M5	M4	1	¾"
SD80 *	4CX4mm ²	-	6	M5	M4	2	¾"
ND80	4CX4mm ²	-	3	M5	M4	1	¾"
ND90S-ND132M	4CX10mm ²	4CX10mm ²	6 #	M6	M5	DOL-1 S/D-2	1"
SD90S-SD100L	4CX10mm ²	-	6	M6	M5	1	1"
NC132S/M	4CX10mm ²	4CX10mm ²	6	M6	M5	DOL-1 S/D-2	1"
ND160-ND200	3CX50mm ²	2X3 C X35mm ²	6	M6	M8	2	1"
ND225 TO ND280	3CX120mm ²	2X3C X95mm ²	6	M8	M12\$	2	1 ½"
ND315S/M/L	3CX300mm ²	2X3 C X 240mm ²	6	M12	M12	2	2"
ND355L/LX	3C x 400 mm ²	2 x 3C x 300 mm ²	6	M16	M12	2	2.5"

* INTEGRAL TERMINAL BOX

3 LEADS UPTO 2.2 kW 2 P/4P & 1.5 kW 6P/8P and below, 6 leads for 2.2 kW 6P/8P & above (For ND Frame only)

\$ M12 FOR 250/280 FRAME & M8 FOR ND225 FRAME



EFF Level 2

NOISE & VIBRATION LEVELS

NOISE LEVEL

The noise level of the motors is restricted to the levels specified in IS 12065. Table below gives the noise level as per IS 12065

Limiting Mean Sound Power Level L_{Wp} in dB (A) for Airborne noise emitted by Rotating Electrical Machines.

Protective Enclosure		IP 44	IP 44	IP 44	IP 44	IP 44	IP 44
Rating kW (or kVA)		Rated Speed (rev. /min.)					
ABOVE	UPTO	960 & below	961 to 1320	1321 to 1900	1901 to 2360	2361 to 3150	3151 to 3750
		Sound Power Level dB (A)					
-	1.1	76	79	80	83	84	88
1.1	2.2	79	80	83	87	89	91
2.2	5.5	82	84	87	92	93	95
5.5	11	85	88	91	96	97	100
11	22	89	93	96	98	101	103
22	37	91	95	97	100	103	105
37	55	92	97	99	103	105	107
55	110	96	101	104	105	107	109
110	220	100	104	106	108	110	112
220	630	102	106	109	111	112	114

Note 1: IP 44 corresponds generally to totally enclosed fan-cooled, closed air circuit air-cooled & similar enclosure (see Is-4691)

VIBRATION.

The motor is said to be in state of vibration if any part of it experiences displacement in any direction. Standard motors comply with normal class of vibration depending on severity as per IS 12075. "Measurement & evaluation of vibration of Rotating Electrical Machines". The limits of vibration levels are given below.

VIBRATION LEVELS :

LIMITS OF VIBRATION SEVERITY IN ROTATING ELECTRICAL MACHINES
MEASURED IN STATE OF FREE SUSPENSION *

Shaft height H, mm	56 to 132		160 to 225		225	
Range of speed	600 to 1500	Above 1500 & Upto 3000	600 to 1500	Above 1500 & Upto 3000	600 to 1500	Above 1500 & Upto 3000
Class of vibration Severity	RMS Value of Vibration Velocity, mm/s					
Normal	1.8	1.8	1.8	2.8	2.8	4.5
Precision A	0.71	0.71	0.71	1.12	-	-
Precision B	0.45	0.45	0.45	0.71	-	-
Precision C	0.28	0.28	0.28	0.45	-	-

* The vibration may be determined in rigid mounting condition but the value of vibration severity shall be agreed by a special agreement between the manufacturer & the user.



EFF Level 2

SPECIAL DESIGNS OFFERED

ELECTRICAL	MECHANICAL
Non Standard Voltage And Frequency Variation	Non Standard Mounting Dimensions
Dual Voltage (1:2 or 1: $\sqrt{3}$ Ratio) Triple Voltage (1: $\sqrt{3}$: 2 Ratio)	Special shaft Extension
Inverter fed Supplies And AC Variable Speed drives	Double shaft Extension
Multispeed Motors Upto 4 different speeds Motors	Separately Ventilated
Energy Efficient Motors	Low Vibration & Noise Level
High Slip Motors	Shock Grade Motors
Motors For Frequent starts/stops/reversals (e.g. crane duty)	Motors for Hazardous areas
Torque Motors	Motors For Dust Laden Atmosphere
High Frequency Motors	Brake Motors
Textiles Motors	Geared Motors
10,12,16,18,24,32 Pole Motors	Special Bearings like Thrust Bearings
Special Performance Requirements	Tacho Mounting
Class H insulated Motors	Non Standard Paint Shade and Painting Procedure for required Dry Film Thickness
Motors With Service Factor	Fabricated Steel Enclosure Alternate Terminal Box Position
Slipring Motors with Bar-wound rotors for Frames 280 to 355	Special Shaft Material
	Stainless Steel/ Brass Hardware Accessories like Resistance Temperature Detectors, Bearing Temperature Detectors, Thermocouples, Plug & Socket
	Custom Size Fabricated terminal box & Terminal Arrangements.
	Canopy





EFF Level 2

PERFORMANCE FIGURES OF TEFC SCR MOTORS EFF LEVEL 2 FOR 50°/70°C

OUTPUT		P O L E	FRAME SIZE	FL RPM	FLC AMPS.	FLT Kg-m	EFFICIENCY (%)			POWER FACTOR			DOL STG.		POT % FLT	GD. ² KGM. ²	NET WT. KG
KW	HP						FL	3/4 LOAD	1/2 LOAD	FL	3/4 LOAD	1/2 LOAD	STG.T % FLT	STG.C % FLC			
0.25	0.33	8	ND80	670	1.30	0.36	52.0	46.0	36.0	0.50	0.42	0.32	170	400	200	0.011	17
0.37	0.50	6	ND80	910	1.10	0.40	69.0	68.0	66.0	0.71	0.63	0.52	210	400	250	0.011	17
		8	ND90S	680	1.40	0.53	65.0	64.0	60.0	0.57	0.50	0.40	170	400	220	0.015	22
0.55	0.75	4	ND80	1410	1.40	0.38	73.0	73.0	69.5	0.73	0.67	0.54	200	500	250	0.007	17
		6	ND80	910	1.60	0.59	69.0	68.0	66.0	0.71	0.63	0.52	200	400	260	0.011	17
		8	ND90L	680	1.80	0.79	69.0	68.0	64.0	0.63	0.54	0.45	150	400	200	0.021	22
0.75	1.00	2	ND80	2820	1.70	0.26	77.0	76.0	74.0	0.81	0.73	0.62	250	600	300	0.003	17
		4	ND80	1410	1.70	0.52	77.0	76.0	74.0	0.78	0.75	0.64	200	500	250	0.007	17
		6	ND90S	935	2.00	0.78	73.0	71.0	69.0	0.72	0.65	0.58	200	400	250	0.015	22
		8	ND100L	700	2.60	1.04	70.0	69.0	64.0	0.58	0.51	0.41	175	400	225	0.030	32
1.10	1.50	2 #	ND80	2820	2.40	0.38	79.0	78.0	76.0	0.82	0.77	0.70	225	600	275	0.004	17
		4	ND90S	1415	2.50	0.76	78.0	76.0	74.0	0.78	0.75	0.64	200	500	250	0.014	22
		6	ND90L	935	2.80	1.15	76.0	76.0	74.0	0.72	0.66	0.58	200	500	250	0.021	25
		8	ND100L	700	3.40	1.53	72.5	71.0	68.0	0.63	0.54	0.44	175	400	225	0.034	35
1.50	2.00	2	ND90S	2830	3.20	0.52	80.0	79.0	77.0	0.82	0.77	0.70	225	600	275	0.006	22
		4	ND90L	1415	3.20	1.03	80.0	79.0	77.0	0.81	0.78	0.71	200	500	250	0.019	25
		6	ND100L	935	3.70	1.56	78.0	78.0	76.0	0.72	0.66	0.58	200	400	250	0.030	32
		8	ND112M	700	4.00	2.09	77.0	77.0	75.0	0.68	0.60	0.52	190	400	240	0.057	45
2.20	3.00	2	ND90L	2830	4.60	0.76	81.0	80.0	78.0	0.82	0.77	0.70	250	600	300	0.008	25
		4	ND100L	1440	4.60	1.49	82.0	81.0	79.0	0.82	0.78	0.72	200	600	250	0.030	32
		6	ND112M	935	5.10	2.29	80.0	80.0	78.0	0.75	0.71	0.63	200	500	250	0.048	45
		8	ND132S	710	5.40	3.02	78.0	78.0	76.0	0.73	0.68	0.61	180	450	230	0.174	68
3.00	4.00	2	ND100L	2865	5.90	1.02	83.0	82.0	80.0	0.85	0.81	0.73	250	600	300	0.022	32
		4	ND100L	1425	6.10	2.05	83.0	82.0	80.0	0.82	0.78	0.72	200	600	250	0.034	36
		6	ND132S	940	6.30	3.11	84.0	83.0	80.0	0.79	0.75	0.68	200	500	250	0.174	68
		8	ND132M	710	7.10	4.12	80.0	79.0	77.0	0.74	0.70	0.62	170	500	220	0.214	79
3.70	5.00	2	ND100L	2840	7.20	1.27	84.5	84.3	82.0	0.85	0.81	0.73	250	600	300	0.022	36
		4	ND112M	1430	7.40	2.52	85.0	85.0	83.0	0.82	0.78	0.72	200	600	250	0.052	45
		6	ND132S	950	7.70	3.79	85.0	84.0	82.0	0.79	0.73	0.63	200	600	250	0.174	68
		8	ND132M	710	8.40	5.08	83.0	83.0	81.0	0.74	0.70	0.62	180	600	230	0.214	79
5.50	7.50	2 #	ND112M	2880	10.00	1.86	86.0	86.0	84.0	0.89	0.85	0.80	250	650	300	0.034	45
		2	ND132S	2865	10.50	1.87	86.0	85.0	83.0	0.85	0.82	0.76	200	600	300	0.034	42
		4	ND132S	1450	10.10	3.69	86.0	85.0	83.0	0.88	0.85	0.75	225	600	275	0.131	68
		6	ND132M	950	11.30	5.64	85.0	84.0	82.0	0.80	0.75	0.68	200	600	250	0.214	79
7.50	10.00	2	ND132S	2880	13.30	2.54	88.0	88.0	86.0	0.89	0.85	0.80	250	600	300	0.062	68
		4	ND132M	1455	13.60	5.02	87.0	86.0	84.0	0.88	0.85	0.75	225	600	275	0.161	79
9.30	12.50	2*	ND132M	2890	16.70	3.13	88.0	87.0	85.0	0.89	0.85	0.80	250	700	300	0.076	79.0
		4 #	ND132M	1460	17.50	6.25	88.5	88.5	86.5	0.84	0.81	0.73	200	600	250	0.310	82.0

- NOTE : 1) EFFICIENCY FIGURES ARE AS PER EFF2 CLASS OF IS 12615-2004
 2) ALL PERFORMANCE FIGURES ARE SUBJECT TO TOLERANCES AS PER IS 325 : 1996
 * FOR 45 / 75 ° C ONLY
 # WITH CLASS F RISE (90°)



EFF Level 2

PERFORMANCE FIGURES OF TEFC SCR MOTORS FOR 50°/70°

OUTPUT		P O L E	FRAME SIZE	FL RPM	FLC AMPS.	FLT Kg-m	EFFICIENCY (%)			POWER FACTOR			DOL STG.		POT % FLT	GD. ² KGM. ²	NET WT. KG
KW	HP						FL	3/4 LOAD	1/2 LOAD	FL	3/4 LOAD	1/2 LOAD	STG.T % FLT	STG.C % FLC			
3.7	5.0	8	ND160M	710	8.0	5.08	83.0	83.0	81.0	0.74	0.70	0.62	150	500	225	0.46	120
5.5	7.5	8	ND160M	710	12.0	7.55	85.0	85.0	83.0	0.74	0.70	0.62	150	500	225	0.46	120
	10.0	6	ND160M	975	11.0	5.49	87.5	87.0	85.0	0.80	0.76	0.68	200	550	250	0.46	120
			8	ND160L	710	12.0	7.55	85.0	85.0	83.0	0.76	0.72	0.64	150	500	225	0.64
9.3	12.5	2	ND160M	2920	17.0	3.10	88.0	87.0	85.0	0.88	0.86	0.78	250	650	300	0.13	125
		4	ND160M	1460	17.0	6.20	88.5	88.5	86.5	0.84	0.81	0.73	175	600	225	0.31	125
		6	ND160L	975	18.0	9.29	87.5	87.0	84.0	0.80	0.76	0.68	200	550	250	0.59	148
		8	ND180M	720	20.0	12.58	86.0	86.0	84.0	0.74	0.70	0.60	175	500	225	0.99	174
11	15	2	ND160M	2920	20.0	3.67	88.5	88.0	86.0	0.88	0.86	0.78	250	650	300	0.13	120
		4	ND160M	1460	21.0	7.34	89.0	89.0	86.0	0.82	0.79	0.70	200	600	250	0.36	120
		6	ND160L	975	22.0	10.99	88.0	87.5	86.0	0.80	0.76	0.68	200	550	250	0.64	146
		8	ND180L	720	24.0	14.88	87.0	87.0	85.0	0.74	0.70	0.60	175	500	225	1.16	205
15	20	2	ND160M	2920	26.0	5.00	89.5	89.5	87.5	0.88	0.86	0.79	250	650	300	0.17	120
		4*	ND160L	1460	27.0	10.01	90.0	90.0	88.0	0.85	0.83	0.75	200	600	250	0.47	146
		6	ND180L	975	29.0	14.98	90.0	90.0	88.0	0.79	0.73	0.66	225	600	275	1.16	205
		8	ND200L	725	33.0	20.15	88.5	88.5	86.5	0.71	0.65	0.55	225	500	275	2.14	270
18.5	25	2	ND160L	2920	32.0	6.17	90.0	90.0	88.0	0.88	0.86	0.79	250	650	300	0.21	146
		4	ND180M	1475	34.0	12.22	91.5	91.5	90.0	0.84	0.80	0.72	200	600	250	0.81	170
		6	ND200L	975	34.0	18.48	91.1	91.1	89.9	0.84	0.80	0.70	200	550	250	1.69	270
		8	ND225S	725	39.0	24.85	89.0	89.0	87.0	0.75	0.71	0.63	175	500	225	3.24	345
22	30	2	ND180M	2940	40.0	7.29	91.0	91.0	89.0	0.84	0.80	0.74	175	600	225	0.44	164
		4	ND180L	1475	40.0	14.53	92.0	92.0	90.0	0.84	0.80	0.72	200	600	250	0.95	205
		6	ND200L	975	40.0	21.98	91.5	91.5	90.1	0.84	0.80	0.70	200	550	250	2.04	270
		8	ND225M	725	46.0	29.56	89.0	89.0	87.0	0.75	0.71	0.63	175	550	225	3.61	375
30	40	2	ND200L	2950	52.0	9.91	91.5	91.0	89.0	0.87	0.84	0.80	200	600	250	0.80	270
		4	ND200L	1475	53.0	19.81	92.0	92.0	90.2	0.86	0.82	0.76	225	600	275	1.62	270
		6	ND225M	980	53.0	29.82	92.0	92.0	90.5	0.85	0.81	0.72	200	550	250	3.61	375
		8	ND250M	735	61.0	39.76	91.0	90.5	88.5	0.75	0.71	0.63	175	550	225	4.82	465
37	50	2	ND200L	2950	64.0	12.22	92.5	92.0	90.0	0.87	0.84	0.80	200	600	250	0.89	270
		4	ND225S	1475	63.0	24.43	92.5	92.5	91.6	0.89	0.86	0.78	250	600	300	2.64	345
		6	ND250M	980	66.0	36.77	93.0	93.0	92.0	0.84	0.80	0.72	225	600	275	4.82	465
		8	ND280S	735	75.0	49.03	91.5	91.5	89.5	0.75	0.71	0.63	200	500	250	8.01	600
45	60	2	ND225M	2955	72.0	14.83	92.5	92.0	90.0	0.94	0.92	0.88	225	650	275	1.87	375
		4	ND225M	1475	76.0	29.72	93.0	93.0	91.5	0.89	0.86	0.78	250	600	300	3.13	375
		6	ND280S	980	79.0	44.72	93.0	93.0	91.0	0.85	0.81	0.73	225	600	275	8.01	600
		8	ND280M	725	91.0	60.46	92.0	92.0	90.5	0.75	0.71	0.63	175	500	225	9.89	630
55	75	2	ND250M	2955	87.0	18.13	93.0	93.0	90.5	0.94	0.92	0.88	175	600	225	2.79	465
		4	ND250M	1475	92.0	36.32	93.5	93.5	92.0	0.89	0.86	0.82	200	600	250	3.45	465
		6	ND280M	980	95.0	54.66	93.5	93.5	92.5	0.86	0.82	0.74	200	600	250	9.89	630
		8	ND315S	740	113.0	72.39	93.0	93.0	91.5	0.73	0.66	0.56	200	550	250	14.10	900
75.0	100.0	2	ND280S	2975	124.0	24.55	93.6	93.5	92.0	0.90	0.86	0.78	225	600	275	7.14	600
		4	ND280S	1480	123.0	49.36	94.0	94.0	92.5	0.90	0.88	0.82	200	600	250	7.21	600
		6	ND315S	987	134.0	74.01	93.5	93.0	91.0	0.83	0.76	0.64	200	600	250	14.10	900
		8	ND315M	740	153.0	98.72	93.5	93.5	91.5	0.73	0.66	0.56	200	550	250	19.00	950

NOTE : 1) EFFICIENCY FIGURES ARE AS PER EFF2 CLASS OF IS 12615-2004

2) ALL PERFORMANCE FIGURES ARE SUBJECT TO TOLERANCES AS PER IS 325 : 1996

* FOR 45 / 75 ° C ONLY



EFF Level 2

PERFORMANCE FIGURES OF TEFC SCR MOTORS FOR 50°/70°

OUTPUT		P O L E	FRAME SIZE	FL RPM	FLC AMPS.	FLT Kg-m	EFFICIENCY (%)			POWER FACTOR			DOL STG.		POT % FLT	GD. ² KGM. ²	NET WT. KG
KW	HP						FL	3/4 LOAD	1/2 LOAD	FL	3/4 LOAD	1/2 LOAD	STG.T % FLT	STG.C % FLC			
90	120	2	ND280M	2975	148.0	29.46	94.0	94.0	92.5	0.90	0.86	0.78	225	600	275	8.2	630
		4	ND280M	1480	147.0	59.21	94.5	94.5	92.5	0.90	0.88	0.82	225	600	275	8.3	630
		6	ND315M	987	156.0	88.79	94.2	94.2	92.5	0.85	0.80	0.70	200	600	250	17.0	950
		8	ND315L	740	180.0	118.43	94.0	94.0	92.0	0.74	0.70	0.60	150	500	225	25.3	1160
110	150	2	ND315S	2965	173.0	36.13	94.0	94.0	92.5	0.94	0.90	0.82	175	600	225	6.6	900
		4	ND315S	1485	176.0	72.13	94.5	94.5	92.0	0.92	0.88	0.80	225	600	275	11.6	900
		6	ND315M	987	188.0	108.52	94.5	94.5	93.0	0.86	0.82	0.74	200	600	250	19.0	950
		8	ND315LX	740	220.0	144.75	94.0	94.0	92.0	0.74	0.70	0.60	150	500	225	29.9	1160
132	180	2	ND315M	2965	207.0	43.35	94.5	94.5	92.5	0.94	0.90	0.82	175	600	225	8.0	950
		4	ND315M	1490	225.0	86.26	95.0	95.0	93.5	0.86	0.82	0.74	225	600	275	14.0	950
		6	ND315L	990	225.0	129.83	95.0	94.5	93.0	0.86	0.82	0.74	200	600	250	25.3	1160
		8	ND315LX	740	263.0	173.70	94.5	94.5	92.5	0.74	0.70	0.60	150	500	225	31.8	1160
150	200	2	ND315L	2975	234.0	49.10	95.0	94.5	92.5	0.94	0.92	0.90	175	600	225	12.4	1160
		4*	ND315M	1490	255.0	98.03	95.0	95.0	93.5	0.86	0.82	0.74	200	600	250	15.6	950
		6	ND315LX	990	255.0	147.54	95.0	94.5	93.0	0.86	0.82	0.74	200	600	250	29.9	1160
		8	ND355L	740	297.0	197.38	95.0	94.0	92.0	0.74	0.70	0.60	150	500	225	36.8	2150
160	215	2	ND315L	2975	249.0	52.37	95.0	94.5	92.5	0.94	0.92	0.90	175	600	225	12.4	1130
		4	ND315L	1488	260.0	104.70	95.3	95.3	94.0	0.90	0.86	0.78	175	600	225	19.0	1160
		6	ND315LX	990	272.0	157.37	95.0	94.5	93.0	0.86	0.82	0.74	200	600	225	29.9	1160
		8	ND355L	740	317.0	210.54	95.0	94.0	92.0	0.74	0.70	0.60	150	500	225	36.8	2150
180	240	2	ND315L	2975	280.0	58.92	95.0	94.5	92.5	0.94	0.92	0.90	175	600	225	13.9	1160
		4	ND315L	1488	292.0	117.79	95.3	95.3	94.0	0.90	0.88	0.84	175	600	225	21.1	1160
		6	ND355L	990	307.0	177.05	95.0	94.5	93.0	0.86	0.82	0.76	200	600	250	33.5	2150
		8	ND355LX	742	340.0	236.22	94.5	94.5	92.0	0.78	0.74	0.66	125	400	225	51.1	2100
200	270	2	ND315LX	2975	310.0	65.46	95.5	95.5	94.0	0.94	0.92	0.90	175	600	225	16.4	1160
		4	ND315LX	1488	324.0	130.88	95.5	95.5	94.0	0.90	0.88	0.84	175	600	225	25.0	1160
		6	ND355LX	990	349.0	196.72	95.0	94.5	93.0	0.84	0.80	0.70	140	500	225	29.7	2150
		8	ND355LX	742	377.0	262.47	94.5	94.5	92.5	0.78	0.74	0.66	125	400	225	58.1	2150
225	300	2	ND355L	2975	352.0	65.00	95.5	95.5	94.0	0.93	0.90	0.84	200	600	250	18.4	2150
		4	ND355L	1488	365.0	147.24	95.5	95.5	93.5	0.90	0.88	0.84	175	600	225	28.0	2150
		6	ND355LX	990	390.0	221.31	95.5	95.0	94.0	0.84	0.80	0.70	140	500	225	31.7	2150
		8*	ND355LX	742	423.0	295.28	94.8	94.5	92.5	0.78	0.74	0.66	125	400	225	58.1	2150
250	335	2	ND355LX	2970	387.0	81.97	95.5	95.0	93.5	0.94	0.92	0.88	150	600	225	27.7	2150
		4	ND355LX	1485	395.0	163.93	95.7	95.7	94.0	0.92	0.88	0.84	150	600	225	29.6	2150
		6	ND355LX	990	434.0	245.90	95.5	95.0	94.0	0.84	0.80	0.70	140	500	225	35.6	2150
		8	ND400LX	744	458.0	327.20	95.0	94.4	92.5	0.80	0.77	0.68	120	400	225	81.8	3200
275	370	2	ND355LX	2980	435.0	91.49	95.5	95.0	93.5	0.92	0.90	0.88	150	600	225	27.7	2150
		4	ND355LX	1485	435.0	183.60	95.7	95.7	94.0	0.92	0.88	0.84	150	600	225	31.6	2150
		6	ND355LX	990	477.0	275.41	95.5	95.0	94.0	0.84	0.80	0.70	140	500	225	39.8	2150
		8	ND400LX	744	503.0	367.05	95.0	94.4	92.5	0.80	0.77	0.68	120	400	225	87.8	3200
315	425	2	ND355LX	2980	499.0	102.93	95.5	95.5	94.0	0.92	0.90	0.88	175	650	225	29.6	2150
		4	ND355LX	1490	525.0	205.86	96.0	96.0	94.5	0.87	0.83	0.73	150	600	225	35.5	2150
		6	ND400LX	994	560.0	308.58	95.5	94.5	93.0	0.82	0.78	0.70	150	500	225	81.8	3200
		8	ND400LX	744	588.0	412.28	95.5	95.0	93.0	0.78	0.75	0.66	120	400	225	97.6	3200
335	452	2	ND355LX	2980	530.0	109.49	95.5	95.5	94.0	0.92	0.90	0.88	150	600	225	29.6	2150
		4	ND355LX	1490	558.0	218.99	96.0	96.0	94.5	0.87	0.83	0.73	150	600	225	39.7	2150

NOTE : 1) EFFICIENCY FIGURES ARE AS PER EFF2 CLASS OF IS 12615-2004 2) ALL PERFORMANCE FIGURES ARE SUBJECT TO TOLERANCES AS PER IS 325 : 1996
* FOR 45 / 75 ° C ONLY # WITH CLASS F RISE (90°)



EFF Level 2

OUTLINE DIMENSION DRAWING FOR 3 PHASE SQUIRREL CAGE TEFC FOOT MOUNTED INDUCTION MOTORS (4 POLE & UP FOR ALL FRAMES & 2 POLE & UP, UPTO ND200L FRAME.)

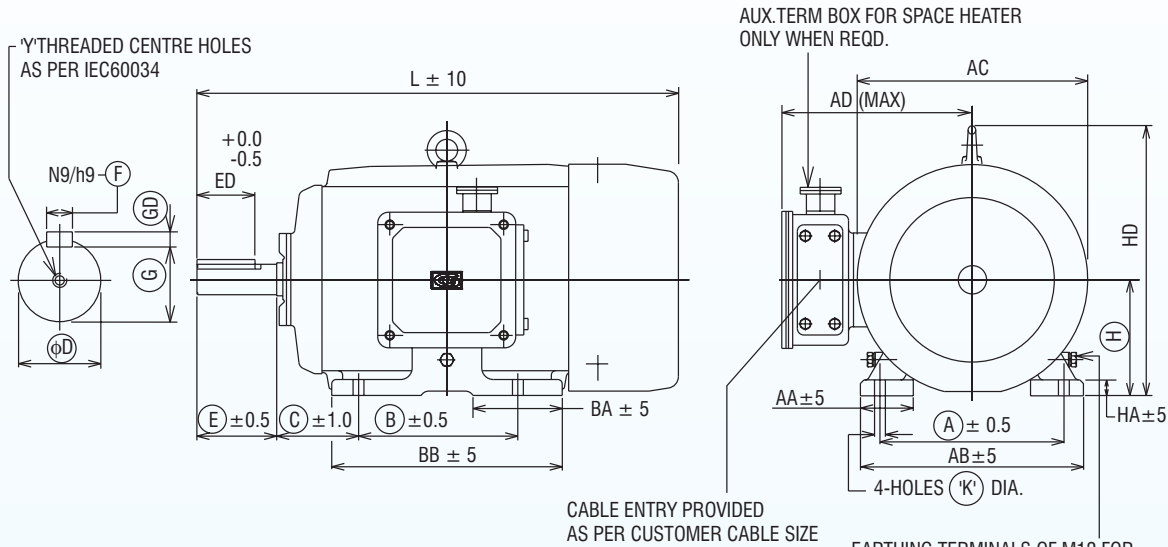

RINGED DIMENSIONS ARE AS PER IEC60034
ALL DIMENSIONS ARE IN mm.

Frame	A	B	C	H	AA	AB	BA	BB	K	D	E	ED	F	GD	G	Y	AD	AC	L	HD	HA
ND80	125	100	50	80.0 79.5	35	152	45	124	10.0 10.5	19.009 18.996	40	27	6.00 5.970	6.00 5.970	15.0 14.8	M6x16	134	170	285	200	11
ND90S ND90L	140	100 125	56	90.0 89.5	35	168	40 52	127 152	10.0 10.5	24.009 23.996	50	36	8.00 7.91	7.00 6.91	20.8 19.8	M8x19	150	195	315 340	230	13
ND100L	160	140	63	100.0 99.5	36	192	45	170	12.0 12.5	28.009 23.996	60	44	8.00 7.91	7.00 6.91	24.0 23.8	M10x22	160	215	370	250	13
ND112M	190	140	70	112.0 111.5	36	222	60	170	12.0 12.5	28.009 23.996	60	44	8.00 7.91	7.00 6.91	24.0 23.8	M10x22	170	235	395	275	13
ND132S ND132M	216	140 178	89	132.0 131.5	48	254	54	178	12.0 12.5	38.018 38.002	80	60	10.0 9.91	8.00 7.91	33.0 32.8	M12x28	190	275	470 510	320	16
ND160M	254	210	108	160.0 159.5	73	308	76	254	15.0 15.5	42.018 42.002	110	80	12.00 11.957	8.00 7.91	37.0 36.8	M16x32	325	318	605	376	22
ND160L	254	254	108	160.0 159.5	73	308	101	298	15.0 15.5	42.018 42.002	110	80	12.00 11.957	8.00 7.91	37.0 36.8	M16x32	325	318	650	376	22
ND180M	279	241	121	180.0 179.5	84	348	85	286	15.0 15.5	48.018 48.002	110	80	14.00 13.957	9.00 8.91	42.5 42.3	M16x32	345	352	677	418	22
ND180L	279	279	121	180.0 179.5	84	348	106	323	15.0 15.5	48.018 48.002	110	80	14.00 13.957	9.00 8.91	42.5 42.3	M16x32	345	352	715	418	22
ND200L	318	305	133	200.0 199.5	66	381	115	356	19.0 19.5	55.030 55.011	110	80	16.00 15.957	10.0 9.91	49.0 48.8	M20x40	430	428	790	480	25
ND225S	356	286	149	225.0 224.5	70	425	102	340	19.0 19.5	60.030 60.011	140	110	18.00 17.957	11.00 10.91	53.0 52.8	M20x40	455	470	840	534	25
ND225M	356	311	149	225.0 224.5	70	425	102	375	19.0 19.5	60.030 60.011	140	110	18.00 17.957	11.00 10.91	53.0 52.8	M20x40	455	470	865	534	25
ND250S	406	311	168	250.0 249.5	80	483	140	419	24.0 24.5	65.030 65.011	140	110	18.00 17.957	11.00 10.91	58.0 57.8	M20x40	485	500	940	598	32
ND250M	406	349	168	250.0 249.5	80	483	140	419	24.0 24.5	65.030 65.011	140	110	18.00 17.957	11.00 10.91	58.0 57.8	M20x40	485	500	940	598	32
ND280S	457	368	190	280.0 279.0	100	538	137	440	24.0 24.5	75.030 75.011	140	110	20.00 19.948	12.00 11.91	67.5 67.3	M20x40	530	536	1035	642	35
ND280M	457	419	190	280.0 279.0	100	538	162	487	24.0 24.5	75.030 75.011	140	110	20.00 19.948	12.00 11.91	67.5 67.3	M20x40	530	536	1085	642	35
ND315S	508	406	216	315.0 314.0	110	597	138	485	28.0 28.5	80.030 80.011	170	140	22.00 21.948	14.00 13.91	71.0 70.8	M20x40	530	590	1180	725	35
ND315M	508	457	216	315.0 314.0	110	597	164	533	28.0 28.5	80.030 80.011	170	140	22.00 21.948	14.00 13.91	71.0 70.8	M20x40	530	590	1230	725	35
ND315L	508	508	216	315.0 314.0	110	610	204	655	28.0 28.5	90.035 90.013	170	140	25.00 24.948	14.00 13.91	81.0 80.8	M24x50	570	655	1295	755	38
ND315LX	508	508	216	315.0 314.0	110	610	235	740	28.0 28.5	90.035 90.013	170	140	25.00 24.948	14.00 13.91	81.0 80.8	M24x50	570	655	1390	755	38
ND355S	610	510	254	355.0 354.0	110	710	253	745	28.0 28.5	100.035 100.013	210	160	28.000 27.948	16.00 15.89	90.0 89.8	M24x50	560	672	1505	780	40
ND355M	610	560	254	355.0 354.0	110	710	253	745	28.0 28.5	100.035 100.013	210	160	28.000 27.948	16.00 15.89	90.0 89.8	M24x50	560	672	1505	780	40
ND355L	610	630	254	355.0 354.0	110	710	253	745	28.0 28.5	100.035 100.013	210	160	28.00 27.948	16.00 15.89	90.0 89.8	M24x50	560	672	1505	780	40
ND355LX	610	630	254	355.0 354.0	110	710	250	880	28.0 28.5	100.035 100.013	210	160	28.000 27.948	16.00 15.89	90.0 89.8	M24x50	600	720	1570	827	40

*FOR 2 POLE MOTORS IN FRAME 225 & ABOVE PLEASE REFER SEPERATE DRAWING.



EFF Level 2

OUTLINE DIMENSION DRAWING FOR 3 PHASE SQUIRREL CAGE TEFC FOOT MOUNTED INDUCTION MOTORS (FOR 2 POLE)

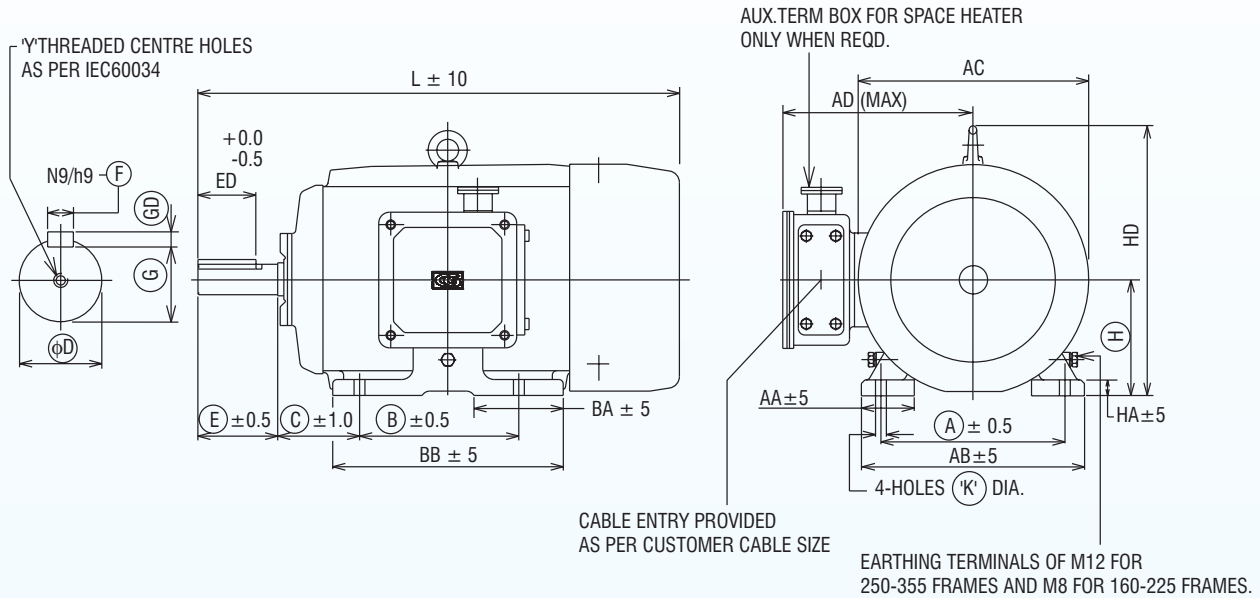

RINGED DIMENSIONS ARE AS PER IEC60034
ALL DIMENSIONS ARE IN mm.

Frame	A	B	C	H	AA	AB	BA	BB	K	D	E	ED	F	GD	G	Y	AD	AC	L	HD	HA
ND225S	356	286	149	224.5 225.0	70	425	102	340	19.0 19.5	55.011 55.030	110	80	16.00 15.957	10.00 9.91	49.0 48.8	M20X40	455	470	810	534	25
ND225M	356	311	149	224.5 225.0	70	425	102	375	19.0 19.5	55.011 55.030	110	80	16.00 15.957	10.00 9.91	49.0 48.8	M20X40	455	470	825	534	25
ND250S	406	311	168	249.5 250.0	80	483	140	419	24.0 24.5	60.011 60.030	140	110	18.00 17.957	11.00 10.91	53.0 52.8	M20X40	485	500	940	598	32
ND250M	406	349	168	249.5 250.0	80	483	140	419	24.0 24.5	60.011 60.030	140	110	18.00 17.957	11.00 10.91	53.0 52.8	M20X40	485	500	940	598	32
ND280S	457	368	190	279.0 280.0	100	538	137	440	24.0 24.5	65.011 65.030	140	110	18.00 17.957	11.00 10.91	58.0 57.8	M20X40	530	536	1035	642	35
ND280M	457	419	190	279.0 280.0	100	538	162	487	24.0 24.5	65.011 65.030	140	110	18.00 17.957	11.00 10.91	58.0 57.8	M20X40	530	536	1085	642	35
ND315S	508	406	216	314.0 315.0	110	597	138	485	28.0 28.5	65.011 65.030	140	110	18.00 17.957	11.00 10.91	58.0 57.8	M20X40	530	590	1150	725	35
ND315M	508	457	216	314.0 315.0	110	597	164	533	28.0 28.5	65.011 65.030	140	110	18.00 17.957	11.00 10.91	58.0 57.8	M20X40	530	590	1200	725	35
ND315L	508	508	216	314.0 315.0	110	610	204	655	28.0 28.5	70.011 70.030	140	110	20.00 19.948	12.00 11.91	62.3 62.5	M20X40	570	655	1265	755	38
ND315LX	508	508	216	315.0 314.0	110	610	235	740	28.0 28.5	70.011 70.030	140	110	20.00 19.948	12.00 11.91	62.5 62.3	M20X40	570	655	1360	755	38
ND355S	610	510	254	354.0 355.0	110	710	253	745	28.0 28.5	75.011 75.030	170	140	20.00 19.948	12.00 11.91	67.3 67.5	M20X40	560	672	1465	780	40
ND355M	610	560	254	354.0 355.0	110	710	253	745	28.0 28.5	75.011 75.030	170	140	20.00 19.948	12.00 11.91	67.3 67.5	M20X40	560	672	1465	780	40
ND355L	610	630	254	354.0 355.0	110	710	253	745	28.0 28.5	75.011 75.030	170	140	20.00 19.948	12.00 11.91	67.3 67.5	M20X40	560	672	1465	780	40
ND355LX	610	630	254	355.0 354.0	110	710	250	880	28.0 28.5	75.011 75.030	170	140	20.00 19.948	12.00 11.91	67.3 67.5	M20X40	600	720	1530	827	40



EFF Level 2

OUTLINE DIMENSION DRAWING FOR 3 PHASE SQUIRREL CAGE TEFC FLANGE MOUNTED INDUCTION MOTORS (4 POLE & UP FOR ALL FRAMES & 2 POLE & UP, UPTO ND200L FRAME.)

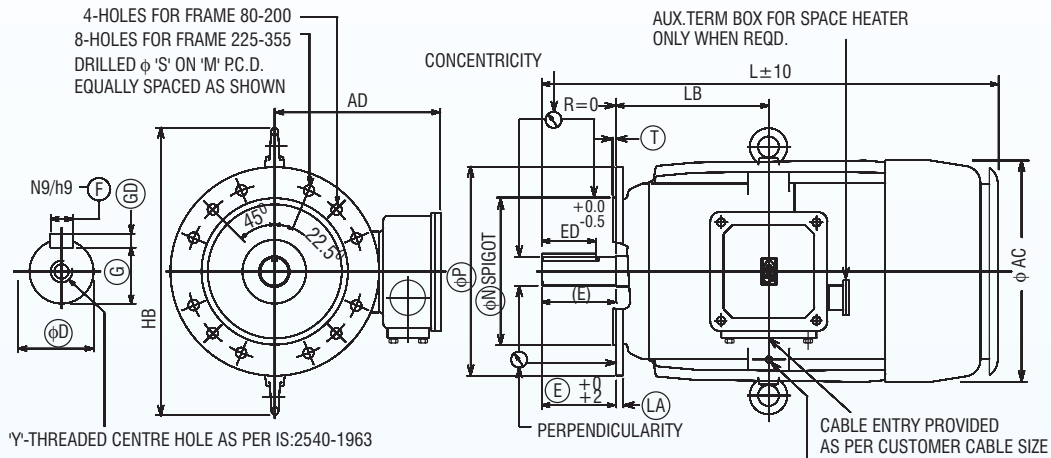

Y-THREADED CENTRE HOLE AS PER IS:2540-1963

EARTHING TERMINALS OF M12 FOR 250-355 FRAMES AND M8 FOR 160-225 FRAMES.

RINGED DIMENSIONS ARE AS PER IS:2223
ALL DIMENSIONS ARE IN mm.

Frame	D	E	ED	F	GD	G	Y	AD	AC	L	M Tol	N Tol	P	S	T	LA	LB	HB
ND80	19.009 18.996	40	27	6.00 5.970	6.00 5.970	15.0 14.8	M6x16	134	170	325	165.30 164.70	130.014 129.989	200	12	3.5	10	100	260
ND90S	24.009	50	36	8.00	7.0	20.0	M8x19	185	195	375	165.30	130.014	200	12	3.5	10	122	280
ND90L	23.996			7.964	6.91	19.8					164.70	129.989						
ND100L	28.009 27.996	60	44	8.00 7.964	7.0 6.91	24.0 23.8	M10x12	195	215	440	215.30 214.70	180.016 179.987	250	15	4.0	11	137	300
ND112M	28.009 27.996	60	44	8.00 7.964	7.0 6.91	24.0 23.8	M10x12	210	235	465	215.30 214.70	180.016 179.987	250	15	4.0	11	140	320
ND132S	38.018	80	60	10.00	8.0	33.0	M12x28	230	275	542	265.30	230.016	300	15	4.0	14	158	380
ND132M	38.002			9.91	7.91	32.8					264.70	229.987						
ND160M	42.018 42.002	110	80	12.00 11.957	8.00 7.91	37.0 36.8	M16X32	325	318	660	300.5 299.5	250.016 249.987	350	19	5	18	213	421
ND160L	42.018 42.002	110	80	12.00 11.957	8.00 7.91	37.0 36.8	M16X32	325	318	705	300.5 299.5	250.016 249.987	350	19	5	18	235	421
ND180M	48.018 48.002	110	80	14.00 13.957	9.00 8.91	42.5 42.3	M16X32	345	352	750	300.5 299.5	250.016 249.987	350	19	5	18	241.5	478
ND180L	48.018 48.002	110	80	14.00 13.957	9.00 8.91	42.5 42.3	M16X32	345	352	790	300.5 299.5	250.016 249.987	350	19	5	18	260.5	478
ND200L	55.030 55.011	110	80	16.00 15.957	10.00 9.91	49.0 48.8	M20X40	430	428	830	350.5 349.5	300.018 299.982	400	19	5	18	285.5	557
ND225S	60.030 60.011	140	110	18.00 17.957	11.00 10.91	53.0 52.8	M20X40	455	470	895	400.5 399.5	350.018 349.982	450	19	5	19	304.5	618
ND225M	60.030 60.011	140	110	18.00 17.957	11.00 10.91	53.0 52.8	M20X40	455	470	895	400.5 399.5	350.018 349.982	450	19	5	19	304.5	618
ND250S	65.030 65.011	140	110	18.00 17.957	11.00 10.91	58.0 57.8	M20X40	485	500	1020	500.5 499.5	450.020 449.980	550	19	5	22	342.5	688
ND250M	65.030 65.011	140	110	18.00 17.957	11.00 10.91	58.0 57.8	M20X40	485	500	1020	500.5 499.5	450.020 449.980	550	19	5	22	342.5	688
ND280S	75.030 75.011	140	110	20.00 19.948	12.00 11.91	67.5 67.3	M20X40	530	536	1170	500.5 499.5	450.020 449.980	550	19	5	22	399.5	722
ND280M	75.030 75.011	140	110	20.00 19.948	12.00 11.91	67.5 67.3	M20X40	530	536	1170	500.5 499.5	450.020 449.980	550	19	5	22	399.5	722
ND315S	80.030 80.011	170	140	22.00 21.948	14.00 13.91	71.0 70.8	M20X40	530	590	1325	601.0 599.0	550.022 549.978	660	24	6	25	444.5	812
ND315M	80.030 80.011	170	140	22.00 21.948	14.00 13.91	71.0 70.8	M20X40	530	590	1325	601.0 599.0	550.022 549.978	660	24	6	25	444.5	812
ND315LX	90.035 90.013	170	140	25.00 24.948	14.00 13.91	81.0 80.8	M24X50	570	655	1495	601.0 599.0	550.022 549.978	660	24	6	25	530.5	880
ND355S	100.035 100.013	210	160	28.00 27.948	16.0 15.89	90.0 89.8	M24x50	570	672	1513	741.0	680.025	800	24	6	28	570	890
ND355M								570	672	1513	741.0	680.025						
ND355L								570	672	1513	741.0	680.025						
ND355LX								600	720	1570	739.0	679.975						



EFF Level 2

OUTLINE DIMENSION DRAWING FOR 3 PHASE SQUIRREL CAGE TEFc FLANGE MOUNTED INDUCTION MOTORS (FOR 2 POLE)

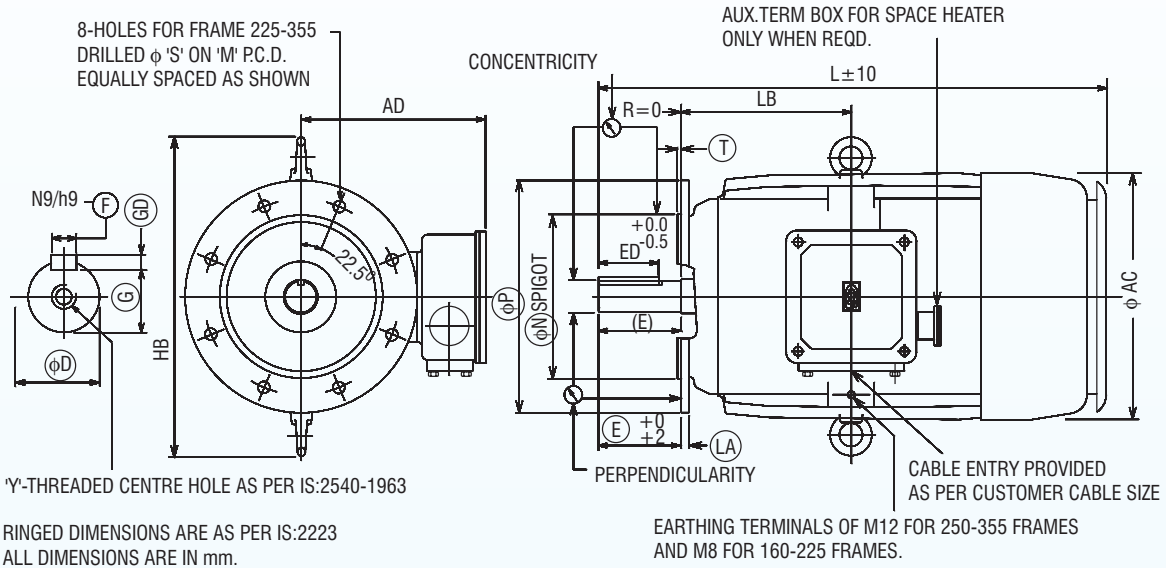

Frame	D	E	ED	F	GD	G	Y	AD	AC	L	M Tol	N Tol	P	S	T	LA	LB	HB
ND225S	55.011 55.030	110	80	16.0 15.957	10.0 9.91	49.0 48.8	M20X40	455	470	865	400.5 399.5	350.018 349.982	450	19	5	19	304.5	618
ND225M	55.011 55.030	110	80	16.0 15.957	10.0 9.91	49.0 48.8	M20X40	455	470	865	400.5 399.5	350.018 349.982	450	19	5	19	304.5	618
ND250S	60.011 60.030	140	110	18.00 17.957	11.00 10.91	53.0 52.8	M20X40	485	500	1020	500.5 499.5	450.020 449.980	550	19	5	22	342.5	688
ND250M	60.011 60.030	140	110	18.00 17.957	11.00 10.91	53.0 52.8	M20X40	485	500	1020	500.5 499.5	450.020 449.980	550	19	5	22	342.5	688
ND280S	65.011 65.030	140	110	18.00 17.957	11.00 10.91	58.0 57.8	M20X40	530	536	1170	500.5 499.5	450.020 449.980	550	19	5	22	399.5	722
ND280M	65.011 65.030	140	110	18.00 17.957	11.00 10.91	58.0 57.8	M20X40	530	536	1170	500.5 499.5	450.020 449.980	550	19	5	22	399.5	722
ND315S	65.011 65.030	140	110	18.00 17.957	11.00 10.91	58.0 57.8	M20X40	530	590	1295	601.0 599.0	550.022 549.978	660	24	6	25	444.5	812
ND315M	65.011 65.030	140	110	18.00 17.957	11.00 10.91	58.0 57.8	M20X40	530	590	1295	601.0 599.0	550.022 549.978	660	24	6	25	444.5	812
ND315LX	70.011 70.030	140	110	20.00 19.948	12.00 11.91	62.5 62.3	M20X50	570	655	1465	601.0 599.0	550.022 549.978	660	24	6	25	530.5	880
ND355S	75.030 75.011	170	140	20.00 19.948	12.00 11.91	67.5 67.3	M20x40	570 600	672 720	1473 1530	741.0	680.025	800	24	6	28	570	890
ND355M											739.0	679.975						
ND355L																		
ND355LX																		



EFF Level 2

DIMENSION DRAWING FOR 3 PHASE TEFC SQUIRREL CAGE FOOT MOUNTED INDUCTION MOTORS

TWO EYE BOLTS FOR LIFTING THE MOTOR
(BOTH EYE BOLTS TO BE USED SIMULTANEOUSLY)

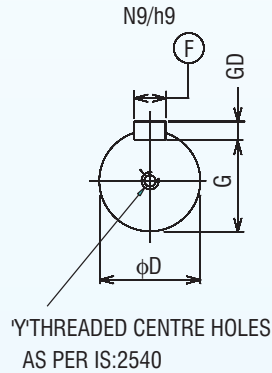
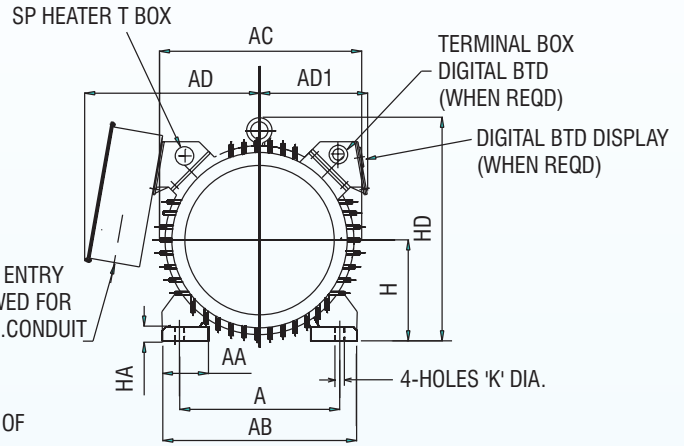
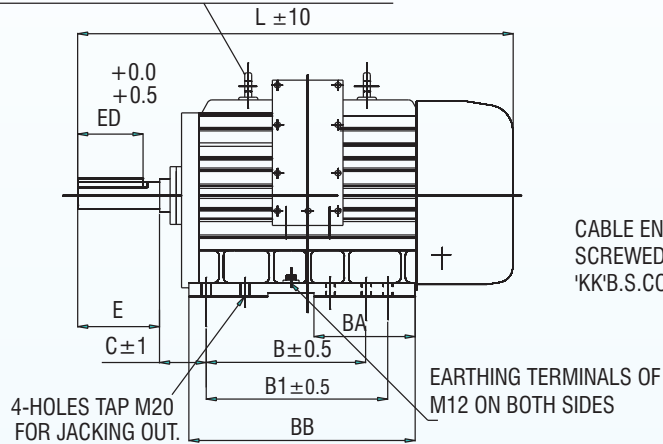

ALL DIMENSIONS ARE IN mm

FRAME SIZE	FOOT FIXING										SHAFT AND KEY *							OVERALL						
	A	B	B1	C	H TOL	AA	AB	BA	BB	K TOL	D TOL	E	ED	F TOL	GD TOL	G	Y	AD	AD1	AC	L	HD	HA	KK
ND400LX 4P & UP	686	800	900	280	400 399	195	845	400	1057	35.0 34.5	100.035 100.013	210	160	28.00 27.948	16.00 15.89	90.0 89.8	M24x50	800	521	875	1855	980	45	2NOS X 3"

MACHINES RUNNING AT 3000 RPM HAVE SMALLER SHAFTS AS SHOWN HERE	FRAME	D TOL	E	ED	F TOL	GD TOL	G	L
	ND400LX	85.035	170	140	22.00	14.00	76.0	1870
	2 POLE	85.013			21.95	13.91	75.8	



Slipring Motors

PERFORMANCE FIGURES OF TEFC SLIPRING MOTORS FOR 45°C / 75°C

OUTPUT		P O L E	FRAME SIZE	FL RPM	FLC AMPS.	EFFICIENCY (%)			POWER FACTOR			OC ROTOR VOLTS	ROTOR CURRENT AMPS	GD. ² KGM. ²	NET WT. kg.
kW	HP					FL	3/4 LOAD	1/2 LOAD	FL	3/4 LOAD	1/2 LOAD				
3.0	4.0	8	NDW160M	690	8.0	80.0	79.0	77.0	0.68	0.64	0.56	230	8.0	0.58	141
3.7	5.0	8	NDW160M	710	9.0	81.0	80.0	78.0	0.68	0.64	0.56	230	10.0	0.58	141
5.5	7.5	6	NDW160M	940	12.0	83.0	82.0	80.0	0.76	0.74	0.66	180	18.5	0.58	141
		8	NDW160L	710	14.0	82.0	81.0	79.0	0.68	0.64	0.56	360	10.0	0.80	165
7.5	10.0	4	NDW160M	1440	15.0	83.0	82.0	80.0	0.84	0.80	0.72	350	13.0	0.48	141
		6	NDW160L	940	17.0	83.0	82.0	80.0	0.76	0.72	0.64	260	19.0	0.77	165
		8	NDW180L	710	18.0	84.0	83.0	81.0	0.68	0.64	0.56	350	13.0	1.58	235
9.3	12.5	4	NDW160L	1440	18.0	84.0	83.0	81.0	0.84	0.80	0.72	350	16.0	0.35	165
		6	NDW180M	950	18.0	86.0	85.0	83.0	0.82	0.78	0.70	230	24.0	1.33	205
		8	NDW200L	725	22.0	86.0	85.0	83.0	0.68	0.64	0.76	300	19.5	2.68	313
11.0	15.0	4	NDW160L	1440	22.0	84.0	83.0	81.0	0.84	0.80	0.72	350	19.0	0.35	165
		6	NDW180L	950	22.0	86.0	85.0	83.0	0.82	0.78	0.70	230	28.5	1.58	235
		8	NDW200L	725	26.0	87.0	86.0	84.0	0.68	0.64	0.56	300	23.0	2.68	313
15.0	20.0	4	NDW180L	1445	28.0	88.0	87.0	85.0	0.84	0.80	0.72	350	27.0	1.26	235
		6	NDW200L	970	29.0	89.0	88.0	86.0	0.82	0.78	0.70	295	31.0	2.68	313
		8	NDW225M	730	34.0	87.0	86.0	84.0	0.70	0.66	0.58	350	27.0	3.06	410
18.5	25.0	4	NDW200L	1470	34.0	89.0	88.0	86.0	0.84	0.80	0.72	300	36.0	2.18	313
		6	NDW225M	970	35.0	89.0	88.0	86.0	0.82	0.78	0.70	310	37.0	2.87	410
		8	NDW225M	730	42.0	88.0	87.0	85.0	0.70	0.66	0.58	360	32.0	3.63	410
22.0	30.0	4	NDW200L	1470	40.0	89.0	88.0	86.0	0.85	0.81	0.73	390	33.0	2.34	313
		6	NDW225M	970	42.0	89.0	88.0	86.0	0.82	0.78	0.70	350	40.0	3.25	410
		8	NDW250M	730	45.0	91.0	90.0	88.0	0.74	0.70	0.62	250	55.0	6.81	513
30.0	40.0	4	NDW225M	1470	55.0	89.0	88.0	86.0	0.85	0.81	0.73	380	47.0	2.96	410
		6	NDW250M	975	56.0	91.0	90.0	88.0	0.82	0.78	0.70	320	56.0	6.81	513
		8	NDW280S	735	62.0	91.0	90.0	88.0	0.74	0.70	0.62	440	43.0	12.89	650
37.0	50.0	4	NDW250M	1475	67.0	91.0	91.0	89.0	0.85	0.81	0.73	425	52.0	4.96	513
		6	NDW280S	980	67.0	91.0	90.0	88.0	0.84	0.80	0.72	410	57.0	12.89	650
		8	NDW280M	735	76.0	91.0	90.0	88.0	0.74	0.70	0.62	520	45.0	15.14	720
45.0	60.0	4	NDW250M	1475	82.0	90.0	89.0	87.0	0.85	0.81	0.73	445	60.0	5.70	513
		6	NDW280M	980	80.0	91.5	91.0	89.0	0.85	0.81	0.73	320	87.0	15.14	720
		8	NDW315S	735	93.0	91.0	90.0	88.0	0.74	0.70	0.62	320	88.0	21.66	950
55.0	75.0	4	NDW280S	1480	97.0	91.5	91.0	89.0	0.86	0.82	0.74	460	73.0	10.61	650
		6	NDW315S	980	98.0	92.0	91.0	89.0	0.85	0.81	0.73	535	62.0	22.00	950
		8	NDW315M	735	112.0	91.0	90.0	88.0	0.75	0.71	0.63	320	108.0	24.16	1000
75.0	100.0	4	NDW280M	1480	130.0	92.5	92.0	90.0	0.87	0.83	0.75	490	92.0	12.45	720
		6	NDW315M	980	132.0	93.0	92.0	90.0	0.85	0.81	0.73	470	96.0	24.16	1000
		8	NDW315LX	730	155.0	91.0	90.0	88.0	0.74	0.67	0.56	357	128.0	28.00	1000
90.0	120.0	4	NDW315S	1480	157.0	92.5	92.0	90.0	0.86	0.82	0.74	505	106.0	18.22	950
		6	NDW315LX	985	169.0	92.5	92.0	90.0	0.84	0.80	0.70	357	140.0	24.26	1220
		8	NDW315LX	735	185.0	91.5	90.5	88.0	0.74	0.67	0.56	410	133.0	33.20	1220
110.0	150.0	4	NDW315M	1485	192.0	92.5	92.0	90.0	0.86	0.82	0.74	500	132.0	20.21	1000
		6	NDW315LX	985	191.0	93.0	92.0	90.0	0.86	0.82	0.74	410	160.0	28.00	1220
		8	NDW355LX	740	224.0	92.5	92.0	90.0	0.74	0.70	0.60	410	170.0	42.60	1260
125.0	175.0	4	NDW315LX	1480	217.0	93.0	92.0	90.0	0.86	0.82	0.70	345	215.0	18.90	1220
		6	NDW315LX	985	211.0	93.8	93.0	91.0	0.88	0.84	0.70	345	214.0	33.20	1220
		8	NDW355LX	740	261.0	92.5	91.5	89.0	0.72	0.66	0.54	460	170.0	47.80	1260
132.0	180.0	4	NDW315LX	1480	230.0	93.0	92.0	90.0	0.86	0.82	0.70	345	227.0	18.90	1220
		6	NDW315LX	985	222.0	94.0	93.0	91.0	0.88	0.84	0.70	345	225.0	33.20	1220
		8	NDW355LX	740	268.0	92.5	91.5	89.0	0.74	0.68	0.56	460	180.0	47.80	1260
150.0	200.0	4	NDW315LX	1480	260.0	93.5	92.5	91.0	0.86	0.82	0.70	440	202.0	23.60	1220
		6	NDW355LX	988	263.0	94.5	94.0	92.0	0.84	0.78	0.66	400	235.0	38.20	1260
		8	NDW355LX	740	292.0	93.0	92.3	90.5	0.77	0.72	0.60	530	174.0	57.20	1260
160.0	215.0	4	NDW315LX	1480	277.0	93.5	92.5	91.0	0.86	0.82	0.70	440	215.0	23.60	1220
		6	NDW355LX	988	280.0	94.5	94.0	92.0	0.84	0.78	0.66	400	250.0	39.60	1260
		8	NDW355LX	740.0	311.0	93.0	92.3	90.5	0.77	0.72	0.60	530.0	185.0	57.2	1260



Slipring Motors

PERFORMANCE FIGURES OF TEFC SR MOTORS FOR 45°C / 75°C

OUTPUT		P O L E	FRAME SIZE	FL RPM	FLC AMPS.	EFFICIENCY (%)			POWER FACTOR			OC ROTOR VOLTS	ROTOR CURRENT AMPS	GD. ² KGM. ²	NET WT. kg.
kW	HP					FL	3/4 LOAD	1/2 LOAD	FL	3/4 LOAD	1/2 LOAD				
180.0	240.0	4	NDW355L	1485.0	317.0	94.0	93.0	91.0	0.84	0.78	0.66	500.0	232.0	25.0	1220
		6	NDW355LX	988.0	315.0	94.7	94.0	92.0	0.84	0.78	0.66	450.0	250.0	44.5	1260
		8	NDW400LX	743.0	357.0	93.5	92.5	90.0	0.75	0.70	0.58	450.0	246.0	87.8	3200
200.0	270.0	4	NDW355L	1485.0	351.0	94.5	93.5	91.5	0.84	0.78	0.66	540.0	239.0	26.6	1260
		6*	NDW355LX	988.0	358.0	94.7	94.0	92.0	0.82	0.76	0.64	480.0	260.0	44.5	1260
		8	NDW400LX	742.0	385.0	93.8	92.8	90.5	0.77	0.72	0.60	450.0	273.0	87.8	3200
225.0	300.0	4	NDW355L	1485	394.0	94.5	94.0	92.5	0.84	0.80	0.70	510	275.0	29.60	1260
		6	NDW400LX	991	397.0	93.8	93.0	91.0	0.84	0.79	0.70	440	320.0	76.60	3200
		8	NDW400LX	742	444.0	93.8	92.8	90.5	0.75	0.68	0.56	510	270.0	94.60	3200
250.0	335.0	4	NDW355LX	1485	449.0	94.5	94.0	92.5	0.82	0.76	0.65	570	275.0	31.60	1260
		6	NDW400LX	991	434.0	94.2	93.5	91.5	0.85	0.80	0.72	440	355.0	76.60	3200
275.0	370.0	4	NDW355LX	1485	486.0	94.8	94.0	92.5	0.83	0.77	0.66	630	275.0	35.50	1260
		6	NDW400LX	992	479.0	94.0	93.2	91.0	0.85	0.80	0.70	475	363.0	81.80	3200
315.0	422.0	4	NDW400LX	1491	549.0	95.0	94.5	93.0	0.84	0.79	0.70	580	328.0	56.40	3200
		6*	NDW400LX	993	560.0	94.3	93.5	91.5	0.83	0.78	0.70	570	345.0	94.60	3200
350.0	470.0	4	NDW400LX	1491	593.0	95.5	95.0	93.5	0.86	0.81	0.71	645	345.0	63.40	3200

FL = Full Load; FLC = Full Load Current; OC = Open Circuit

NOTE : All performance figures are subject to tolerances as per IS 325 - 1996

* ROTOR WITH CLASS F TEMPERATURE RISE



Slipring Motors

OUTLINE DIMENSION DRAWING FOR 3 PHASE SLIP RING TEFC FOOT MOUNTED SINGLE/DOUBLE SHAFT INDUCTION MOTORS CONFORMING TO IS:1231-1974

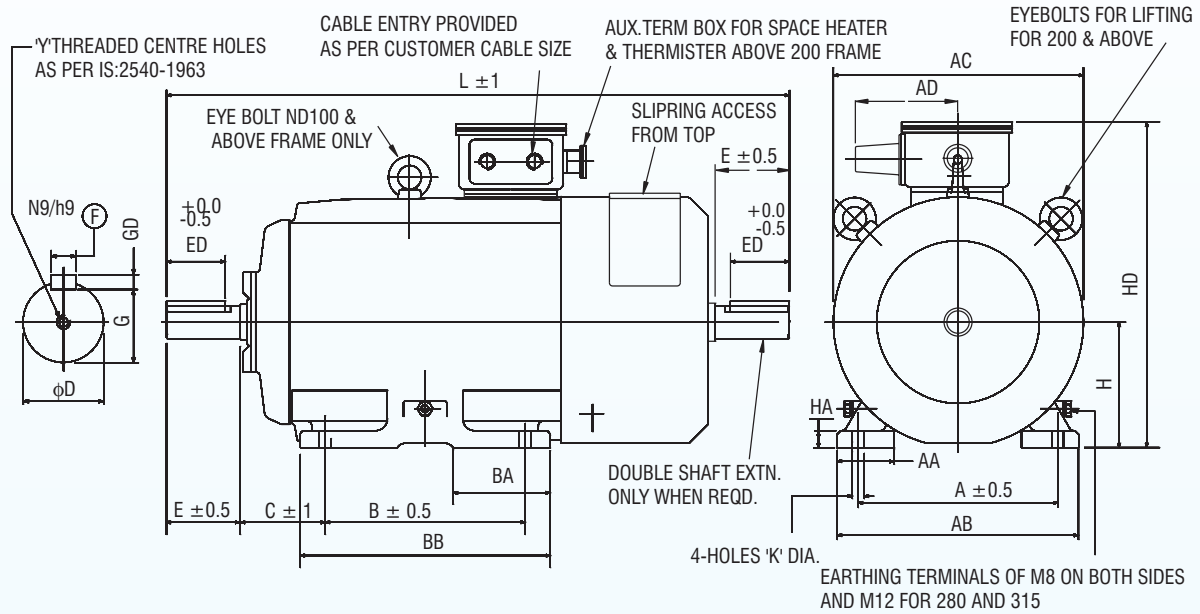

ALL DIMENSION ARE IN mm.

FRAME SIZE	FOOT FIXING									SHAFT AND KEY *						OVERALL																						
	A	B	C	H TOL.	AA	AB	BA	BB	K TOL.	D TOL.	E	ED	F TOL.	GD TOL.	G	Y	AD	AC	L	HD	HA																	
NDW 112M	190	140	70	112.0 111.5	36	222	50	170	12.5 12.0	28.018 28.002	60	44	8.000 7.964	7.00 6.91	24.0 23.8	M10X22	-	235	608	322	13																	
DW 132S	216	140	89	132.0	48	254	54	178	12.5	38.018	80	60	10.00	8.00	33.0	M12X28	-	275	680	362	16																	
DW 132M		178		131.5				216											12.0			38.002	9.964	7.91	32.8	720												
NDW 160M	254	210	108	160.0	73	308	76	254	15.5	42.018	110	80	12.00	8.00	37.0	M16x32	-	318	904	485	22																	
NDW 160L		254		159.5				298											15.0			42.002	11.957	7.91	36.8	948												
NDW 180M	279	241	121	180.0	84	348	95	286	15.5	48.018	110	80	14.00	9.00	42.5	M16x32	-	352	986	525	22																	
NDW 180L		279		179.5				323											15.0			48.002	13.957	8.91	42.3	1030												
NDW 200L	318	305	133	200.0 199.5	66	381	115	356	19.5 19.0	55.030 55.011	110	80	16.00 15.957	10.00 9.91	49.0 48.8	M20X40	-	428	1072	630	25																	
NDW225S	356	286	149	225.0	70	425	102	375	19.5	60.030	140	110	18.00	11.00	53.0	M20X40	285	470	1202	600	25																	
NDW225M		311		224.5				19.0											60.011			17.957	10.91	52.8	1227													
NDW250S	406	311	168	250.0	80	483	135	419	24.5	65.030	140	110	18.00	11.00	58.0	M20X40	285	500	1298	730	32																	
NDW250M		349		249.5				24.0											65.011			17.957	10.91	57.8	1298													
NDW280S	457	368	190	280.0	100	538	135	436	24.5	75.030	140	110	20.00	12.00	67.5	M20X40	285	536	1378	810	35																	
NDW280M		419		279.0				24.0											75.011			19.948	11.91	67.3	1429													
NDW315S	508	406	216	315.0	110	597	138	482	28.5	80.030	170	140	22.00	14.00	71.0	M20X40	375	588	1544	845	38																	
NDW315M		457		314.0				28.0											80.011			21.948	13.91	70.8	1595													
NDW315M/L	508	457/508	216	315.0	110	610	204	655	28.5	90.035	170	140	25.00	14.00	81.0	M24X50	420	655	1665	885	38																	
NDW315LX		508		314.0				28.0											90.013			24.945	13.91	80.8	1750													
NDWI355S	610	500	254	355.0	110	710	253	745	28.5	100.035	210	160	28.00	16.00	90.0	M24X50	420	672	1960	950	40																	
NDWI355M		560						354.0											28.0			100.013	27.948	15.89	89.8	720												
NDWI355L		630						254											355.0			110	710	253	745	28.5	100.035	210	160	28.00	16.00	90.0	M24X50	420	672	1960	950	40
NDWI355LX																																						



Slipring Motors

DIMENSION DRAWING FOR 3 PHASE TEFC SLIPRING FOOT MOUNTED INDUCTION MOTORS

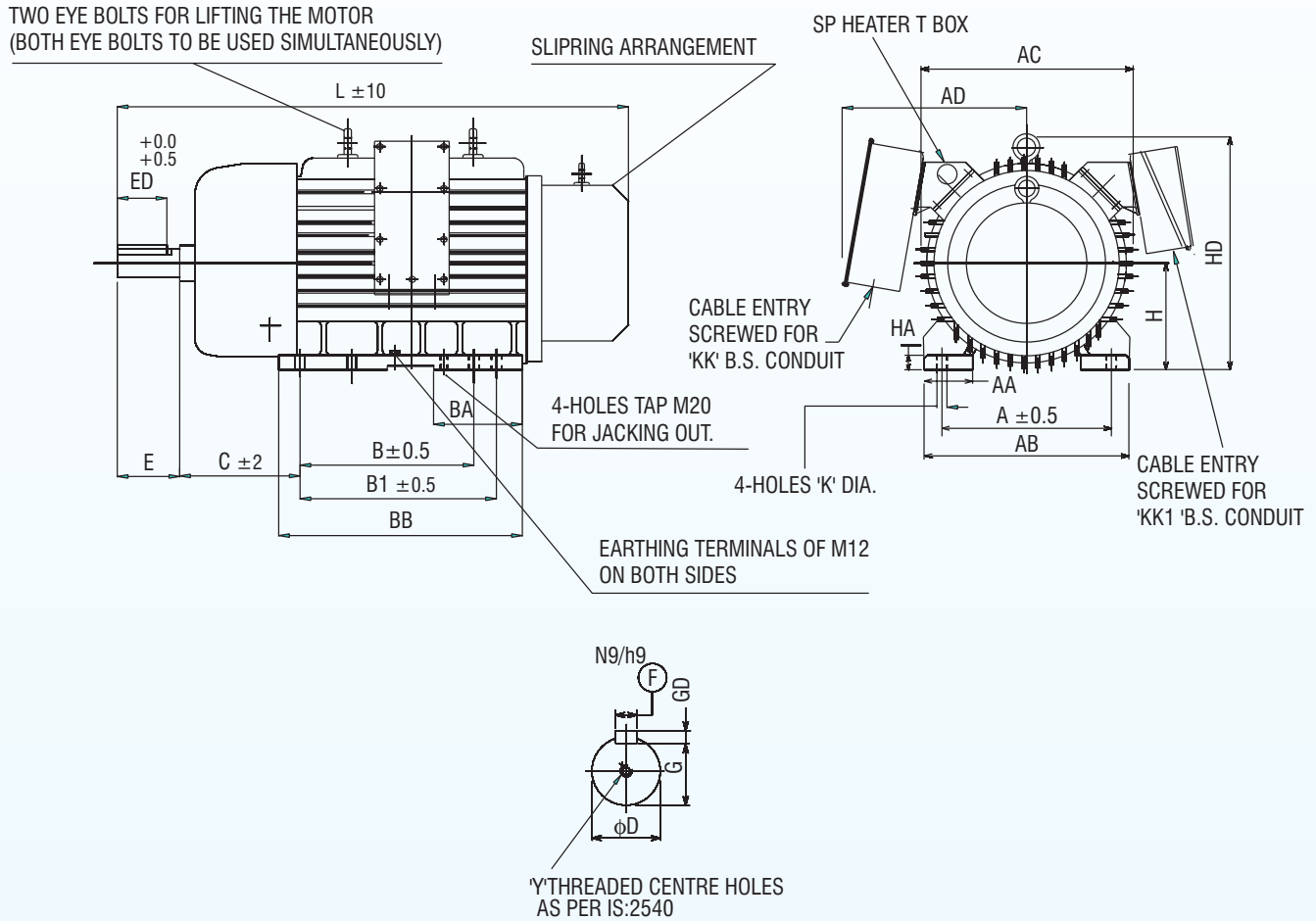

ALL DIMENSIONS ARE IN mm

FRAME SIZE	FOOT FIXING										SHAFT AND KEY *							OVERALL						
	A	B	B1	C	H	AA	AB	BA	BB	K	D	E	ED	F	GD	G	Y	AD	AC	L	HD	HA	KK	KK1
NDW400LX	686	800	900	450	400 399	195	845	400	1057	35.0 34.5	100.035 100.013	210	160	28.00 27.948	16.00 15.89	90.0 89.8	M24x50	800	860	2180	1060	45	2 NOS X 3"	2 NOS X 3"



SPDP Slipring Motors

PERFORMANCE FIGURES OF SPDP SLIPRING MOTORS FOR 45°C / 75°C

OUTPUT		P O L E	FRAME SIZE	FL RPM	FLC Amp	EFFICIENCY (%)			POWER FACTOR			OC Rotor Volts	Rotor Curr. Amp	GD. ² kGm ²	POT %FLT	WT. kg.
KW	HP					FL	3/4 Load	1/2 Load	FL	3/4 Load	1/2 Load					
3.7	5.0	8	CW160M	700	10	78.0	77.0	75.0	0.68	0.64	0.56	230	9	0.51	270	130
5.5	7.5	6	CW160M	935	14	80.0	79.0	77.0	0.72	0.68	0.60	280	13	0.51	270	130
		8	CW160L	700	14	80.0	79.0	77.0	0.68	0.64	0.56	235	15	0.65	270	150
7.5	10.0	4	CW160M	1410	16	82.0	81.0	79.0	0.82	0.78	0.70	375	12	0.41	270	130
		6	CW160L	935	17	83.0	82.0	80.0	0.72	0.68	0.60	260	19	0.65	270	150
		8	CW180M	705	19	82.0	81.0	79.0	0.68	0.64	0.56	350	13	1.14	270	200
9.3	12.5	4	CW160L	1420	19	83.0	82.0	80.0	0.82	0.78	0.70	380	16	0.53	280	150
		6	CW180M	940	19	83.0	82.0	80.0	0.82	0.78	0.70	300	20	1.14	260	200
		8	CW180L	705	24	82.0	81.0	79.0	0.68	0.64	0.56	345	17	1.45	270	220
11.0	15.0	4	CW160L	1420	22	84.0	82.0	80.0	0.82	0.78	0.70	390	18	0.53	280	150
		6	CW180M	940	23	83.0	82.0	80.0	0.82	0.78	0.70	500	14	1.14	260	200
		8	CW180L	705	27	82.0	81.0	79.0	0.70	0.66	0.58	345	20	1.45	270	220
15.0	20.0	4	CW180M	1420	31	83.0	82.0	80.0	0.82	0.78	0.70	390	23	0.53	280	150
		6	CW180L	945	31	83.0	82.0	80.0	0.82	0.78	0.70	510	18	1.33	260	220
		8	CW200M	720	35	84.0	83.0	81.0	0.71	0.67	0.59	240	40	2.20	210	275
18.5	25.0	4	CW180M	1420	36	84.0	83.0	81.0	0.86	0.80	0.72	480	23	0.91	290	200
		6	CW200M	960	38	86.0	85.0	83.0	0.78	0.74	0.66	515	23	2.20	260	275
		8	CW200L	720	43	84.0	83.0	81.0	0.72	0.68	0.60	235	50	2.20	220	299
22.0	30.0	4	CW180L	1420	42	86.0	85.0	83.0	0.84	0.80	0.72	480	28	1.16	300	220
		6	CW200L	965	46	86.0	85.0	83.0	0.78	0.74	0.66	485	28	2.30	280	299
		8	CW225M	720	49	86.0	85.0	83.0	0.73	0.69	0.61	235	60	3.35	210	380
30.0	40.0	4	CW200M	1440	57	87.0	86.0	84.0	0.84	0.80	0.72	470	39	1.79	300	275
		6	CW225M	965	60	88.0	87.0	85.0	0.78	0.74	0.66	536	35	3.35	260	380
		8	CW225M	720	65	87.0	86.0	84.0	0.74	0.70	0.62	235	80	3.35	210	380
37.0	50.0	4	CW200L	1440	70	87.0	86.0	84.0	0.84	0.80	0.72	430	52	2.11	320	299
		6	CW225M	970	74	89.0	88.0	86.0	0.78	0.74	0.66	536	42	3.35	260	390
		8	CW250S	720	79	89.0	88.0	86.0	0.74	0.70	0.62	465	50	5.70	240	455
45.0	60.0	4	CW225M	1450	82	89.0	88.0	86.0	0.85	0.81	0.73	576	49	2.65	320	380
		6	CW250S	970	88	89.0	88.0	86.0	0.80	0.76	0.68	507	53	5.70	230	455
		8	CW250M	725	95	89.0	88.0	86.0	0.74	0.70	0.62	480	59	6.66	250	525
55.0	75.0	4	CW225M	1460	102	89.0	88.0	86.0	0.84	0.80	0.72	576	59	2.65	320	380
		6	CW250M	975	104	90.0	89.0	87.0	0.82	0.78	0.70	515	65	6.66	250	525
		8	CW280S	730	109	90.0	89.0	87.0	0.78	0.74	0.66	425	79	10.65	260	635
75.0	100.0	4	CW250S	1460	135	90.5	90.0	88.0	0.84	0.80	0.72	505	88	4.77	240	455
		6	CW280S	975	134	91.5	91.0	89.0	0.85	0.81	0.73	300	154	10.09	280	635
		8	CW280M	730	149	90.0	89.0	87.0	0.78	0.74	0.66	535	83	13.44	260	750
90.0	120.0	4	CW250MX	1460	158	92.0	91.0	89.0	0.86	0.82	0.74	500	110	7.15	280	695
		6	CW280M	975	160	92.0	91.0	89.0	0.85	0.81	0.73	360	160	13.44	280	750
		8	CW315S	730	180	91.5	91.0	89.0	0.76	0.72	0.64	490	112	19.16	250	870
110.0	150.0	4	CW280M	1455	198	91.0	90.0	88.5	0.85	0.80	0.70	250	275	9.23	280	635
		6	CW315S	973	196	92.0	91.5	90.0	0.85	0.82	0.76	290	250	17.50	275	870
		8	CW315MX	730	218	91.0	91.0	89.0	0.77	0.73	0.65	350	190	21.66	250	980
132.0	175.0	4	CW280MX	1460	227	92.0	92.0	91.0	0.88	0.84	0.72	300	275	11.07	300	750
		6	CW315MX	975	234	92.5	92.0	91.0	0.85	0.82	0.76	345	250	20.83	275	980
		8	CW355L	740	265	93.5	92.5	90.5	0.74	0.67	0.55	410	200	40.30	300	1200
160.0	215.0	4	CW315M	1470	279	94.0	93.5	92.5	0.85	0.80	0.70	420	230	14.64	300	870
		6	CW315MX	980	299	93.0	92.5	91.0	0.80	0.75	0.68	470	225	26.66	350	980
		8	CW355L	740	326	93.6	92.7	91.0	0.73	0.66	0.54	490	203	47.80	300	1200
180.0	240.0	4	CW315MX	1470	306	93.0	92.5	91.0	0.88	0.85	0.78	465	206	17.43	300	980
		6	CW355L	980	319	93.5	92.5	91.0	0.84	0.79	0.69	380	300	36.30	300	1200
		8	CW355L	740	361	93.8	93.0	91.5	0.74	0.67	0.55	525	213	51.00	300	1200
200.0	270.0	4	CW315MX	1475	342	93.5	93.0	91.0	0.87	0.84	0.76	580	225	20.91	350	980
		6	CW355L	975	346	93.5	92.5	91.0	0.86	0.81	0.72	380	330	36.30	300	1200
		8	CW355L	740	411	94.0	93.5	92.0	0.72	0.65	0.52	560	222	53.90	275	1200
225.0	300.0	4	CW315MX	1475	378	94.0	93.5	92.0	0.88	0.85	0.78	580	250	22.20	300	980
		6	CW355L	980	396	94.0	93.0	91.0	0.84	0.79	0.69	425	330	38.70	300	1200
250.0	335.0	4	CW355L	1480	440	94.0	93.5	92.0	0.84	0.80	0.72	510	305	28.00	300	1200
		6	CW355L	980	440	94.0	93.0	91.0	0.84	0.80	0.70	450	350	40.70	300	1200



SPDP Slipping Motors

OUTLINE DIMENSION DRAWING FOR 3 PHASE SPDP SLIPRING FOOT MOUNTED INDUCTION MOTORS.

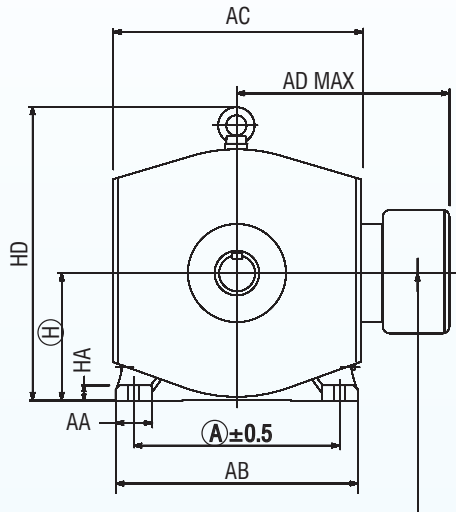

CABLE ENTRY PROVIDED AS PER CUSTOMER CABLE SIZE

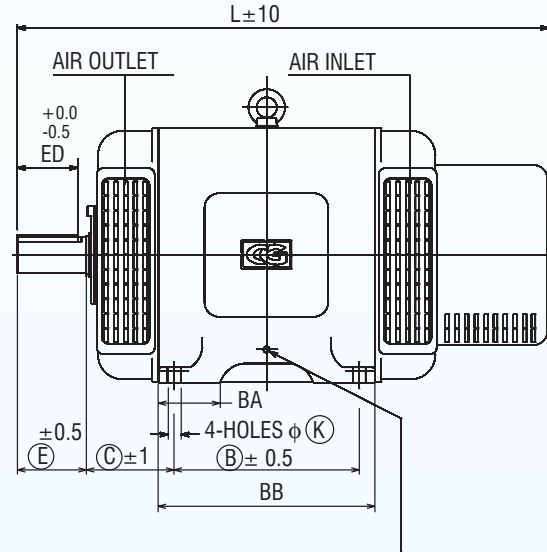

EARTHING TERMINALS OF M8 SIZE ON BOTH SIDES

Y-THREADED CENTRE HOLES
AS PER IS:2540-1963

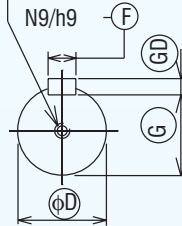

ALL DIMENSIONS ARE IN mm.

FRAME SIZE	FOOT FIXING										SHAFT & KEY						OVERALL				
	A	B	C	H TOL.	AA	AB	BA	BB	K TOL.	D TOL.	E	ED	F TOL.	GD TOL.	G	Y	AD	AC	L	HD	HA
CW160M	254	210	108	160.0	54	298	76	254	15.5	48.018	110	80	14.0	9.00	42.5	M16x32	290	390	680	395	22
CW160L		254		159.7				298	15.0	48.002			13.957	8.91	42.3			724			
CW180M	279	241	121	180.0	60	337	95	285	15.5	55.030	110	80	16.0	10.00	49.0	M20x40	335	420	802	445	22
CW180L		279		179.7				323	15.0	55.011			15.957	09.91	48.8				840		
CW200M	318	267	133	200.0	65	381	105	318	19.5	60.030	140	110	18.0	11.00	53.0	M20x40	398	460	877	498	25
CW200L		305		199.5				355	19.0	60.011			17.957	10.91	52.8				915		
CW225M	356	311	149	225.0 224.5	70	426	125	427	19.5 19.0	65.030 65.011	140	110	18.0 17.957	11.00 10.91	58.0 57.8	M20x40	398	450	1000	520	25



SPDP Slipping Motors

OUTLINE DIMENSION DRAWING FOR 3 PHASE SPDP INTERNAL SLIPRING FOOT MOUNTED INDUCTION MOTORS.

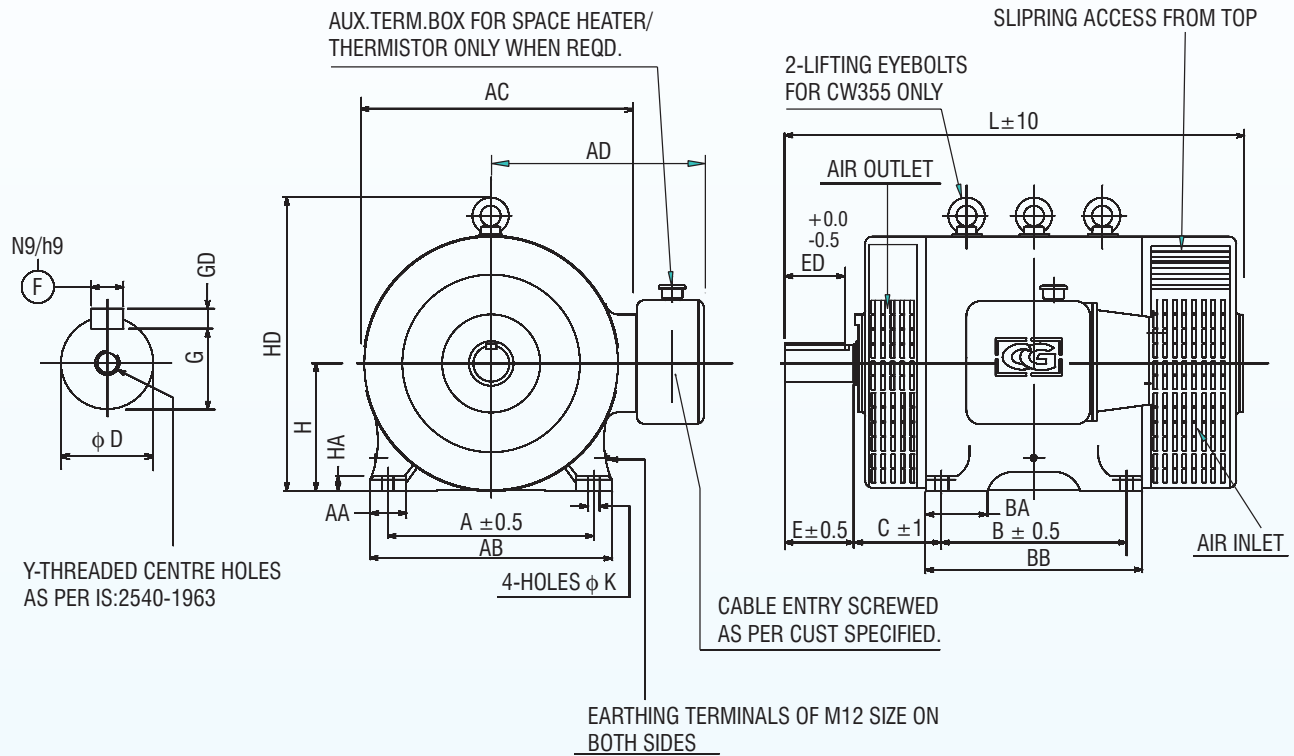

FRAME SIZE	FOOT FIXING									SHAFT & KEY						OVERALL					
	A	B	C	H	AA	AB	BA	BB	K	D	E	ED	F	GD	G	Y	AD	AC	'L'	HD	HA
CW250S	406	311	168	250	80	483	127	381	24.5	75.030	140	110	20.00	12.00	67.5	M20x40	428	500	970	605	28
CW250M		349		249.5				419	24.0	75.011			19.948	11.91	67.3				1005		
CW250MX																					
CW280S	457	368	190	280.0	83	540	146	438	24.5	80.030	170	140	22.00	14.00	71.0	M20x40	515	560	1050	663	35
CW280M		419		279.0				489	24.0	80.011			21.948	13.91	70.8				1121		
CW280MX																					
CW315S	508	406	216	315.0	89	597	184	28.0	90.035	170	140	25.00	14.00	81.0	M24x50	576	630	1240	734	38	
CW315M		457		314.0			153	533	28.5			90.013	24.948	13.91				80.8			1370
CW315MX																					
CW355M	610	560	254	355	89	730	250	860	28.5	100.035	210	160	28.000	16.00	90.0	M24x50	600	780	1670	827	40
CW355L		630		354																	

Energy Efficient Motors - Level I

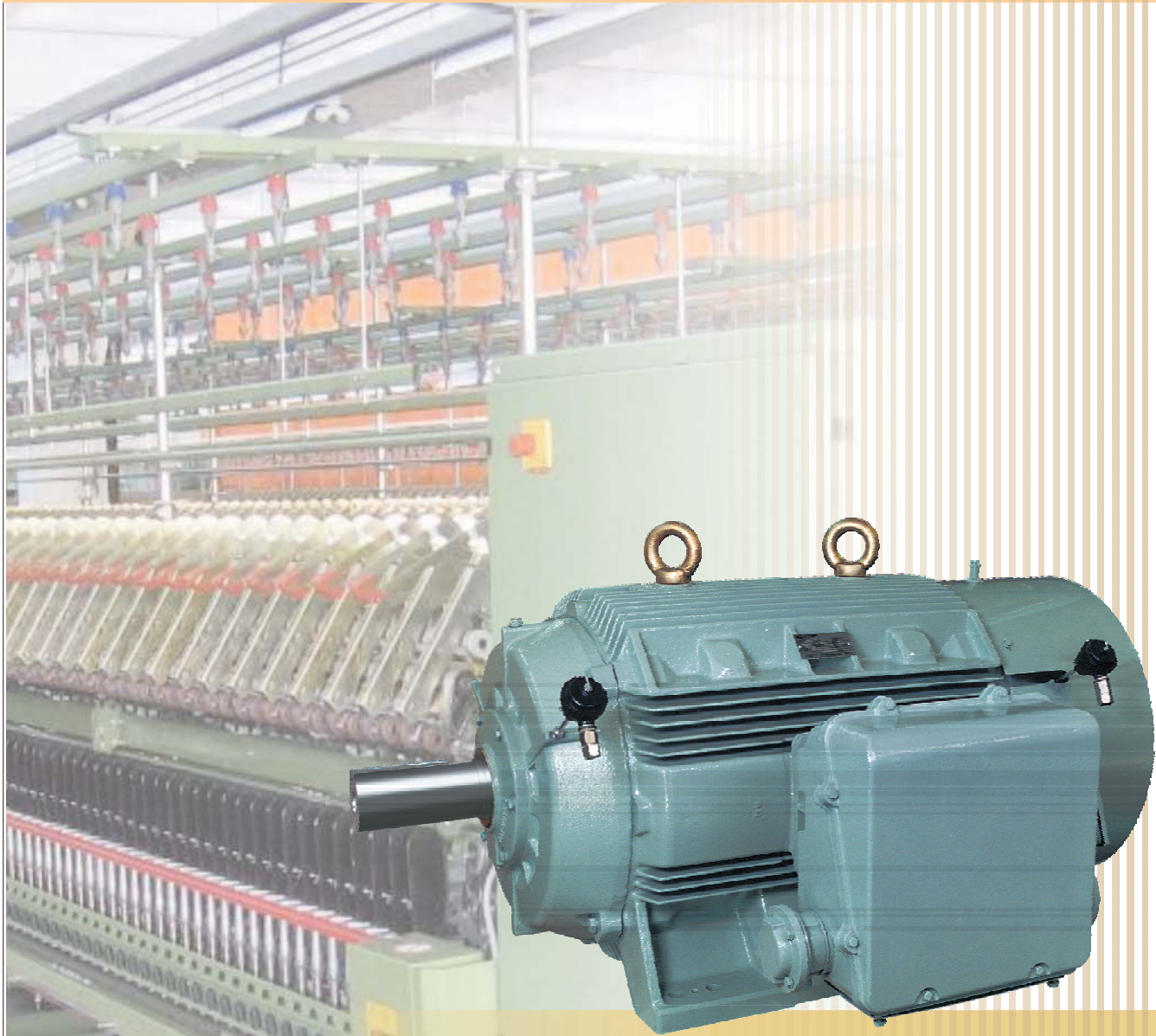

0.37 kW to 160 kW
From 80 to 315 Frame



EFF Level 1

ENERGY EFFICIENT MOTORS LEVEL 1

Crompton Greaves has now developed a complete family of high efficiency motors confirming to Eff level 1 standards of IEEMA : 19-2000 and other applicable standards in Europe and rest of the world.

These motors are available in TEFC construction for use in safe areas and also in flameproof enclosure for use in Hazardous areas.

SPECIAL DESIGN FEATURES :

Higher efficiencies are achieved by following special features :

- Low loss special grade of thinner laminations. This reduces the Iron loss even at partial loads.
- Thicker conductors and more copper contents reduce copper loss due to lower resistance.
- Longer core length, reduced and uniform air gap between stator and rotor to reduce stray losses .
- Special design of fan and fan cover to reduce windage losses.

BENEFITS :

Improved efficiency is available from 60 % to 100 % load. The eff curve is almost flat resulting in higher energy savings as in most of the cases the motor is not always fully loaded .

The special design features also result in lower operating temperatures which enhance the life of motor and reduce the maintenance costs.

These motors have inherently low noise and vibration and help in conservation of environment .

Crompton Greaves energy efficient motors offer an additional feature which no other manufacturer offers.

These motors are with highest power factor in the industry due the special exclusive designs available with Crompton Greaves.

The higher power factor reduces the currents in the cables supplying power to motor and this reduces cable loss, improving the system efficiency sometimes by even 2 %.

Sometimes this allows even a lower cable size saving tremendously on capital costs. Saving is also made by reducing capacitors required to improve power factor.

MANUFACTURING RANGE :

Efficiency Level 1

- 0.37 kW to 160 kW
- Frame sizes : 71 to 315 for TEFC
80 to 315 for Flame proof
- The entire range is available in IEC frames sizes (metric range) and also in NEMA frames

CONFORM TO FOLLOWING STANDARDS :

- IEEMA : 19-2000
- IS 12615
- IS 325-1996 & IEC 60034
- NEMA EPACT EFFICIENCY VALUES (for NEMA motors)

IEEMA 19-2000 standard covers kW ratings only up to 160kW. However we are offering energy efficient motors up to 450 kW.

IMPORTANCE OF ENERGY EFFICIENCY :

Growing cost of energy calls for power saving at each possible step of manufacturing. Electric motor driven systems used in industrial processes consume more than 70 percent of electricity used in industry, hence best possible technology is being applied for achieving highest possible efficiency values.

EFFICIENCY MEASUREMENT OF AN ELECTRIC MOTOR

The efficiency of an electric motor is determined by the amount of useful power it produces compared to the amount of energy required to operate it. The figure below illustrates how a Crompton Greaves Energy efficient motor effectively turns 1000 units of electrical power into mechanical power.

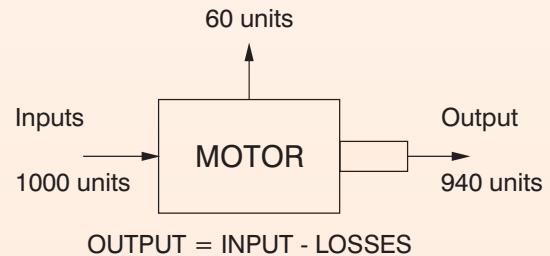

Since motor efficiency is commonly expressed as a percentage. Efficiency in this case would be 94%.





EFF Level 1

APPLICATIONS :

The benefits of using these motors are maximum in continuous duty applications like Blowers, Compressors, Fans, Exhausters Pumps etc.

BEST PERFORMANCE EVEN AT PARTIAL LOADS :

In many applications the load factor of the motor will range between 60% to 80%. The efficiency curve of standard motor is drooping in nature i.e there is a sharp fall in efficiency at partial loads. But the energy efficient motors have a flat efficiency curve and hence the fall in efficiency is marginal. Thus energy saving is significant even in part loads.

15 kW 4 pole efficiency pattern

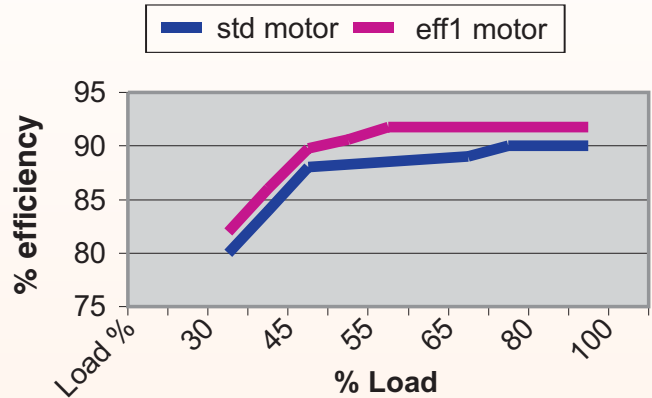

INTERNATIONAL APPROVALS & CERTIFICATES



008





EFF Level 1

ASSESSING COST EFFECTIVENESS OF ENERGY EFFICIENT MOTORS :

Savings :

Savings are calculated as follows :-

- kW - out put of motor in kW
- E1 - efficiency of standard motor
- E2 - efficiency of energy efficient motor

$$X = \left(\frac{\text{kW}}{E1} - \frac{\text{kW}}{E2} \right)$$

$$\text{Savings} = X * \left(\frac{\text{working Hour's}}{\text{days}} \right) * \left(\frac{\text{working days}}{\text{year}} \right) * \left(\text{tariff} \right)$$

EXAMPLE

3.7 kW 4 pole motor in frame ND112M
 Std motor eff 2: 85 % eff1 88.3 %
 Price eff2 : Rs 7215/- eff1: Rs 9380/-
 Working hours 16 per day, working days 300 in a year,
 power rate Rs 4.50 per kWh

$X = 0.1626$
 RS Savings = $0.1626 \times 16 \times 300 \times 4.5$
 = 3514 /- RS per year
 Extra investment RS 2615/-
 Payback period = 9 months

Energy cost for a 15 years usage at Rs 4.50 / kWh is staggering 14.10 lacs as compared to buying cost of Rs 7215/-. Also the energy kWh rate is likely to only go up in future.

If we compare initial purchase price of the motor with the cost of energy it uses over its working lifetime, the initial cost represents less than two percent of its lifetime cost in most of the cases .

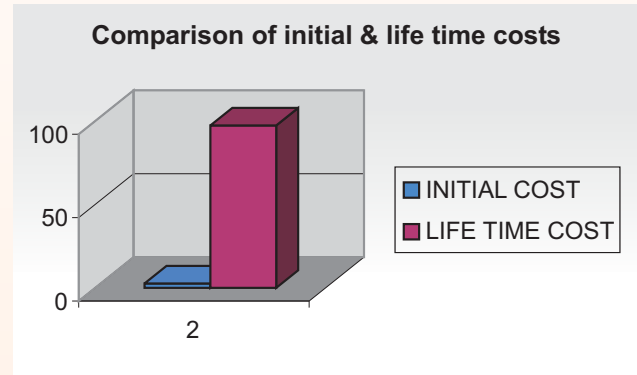

So it makes a great deal of sense to choose an eff1 level motor whenever a motor is needed to drive any applications.

Combining this with usual Crompton greaves motors reliability, wide service network (over 180 service points all over India), the wise choice is Crompton greaves EFF1 motor.





EFF Level 1

PERFORMANCE FIGURES OF TEFC SCR MOTORS FOR 50°/70°- EFF LEVEL 1

OUTPUT		P O L E	FRAME SIZE	FL RPM	FLC AMPS.	FLT Kg-m	EFFICIENCY (%)			POWER FACTOR			DOL STG.		POT % FLT	GD. ² KGM. ²	NET WT. KG
KW	HP						FL	3/4 LOAD	1/2 LOAD	FL	3/4 LOAD	1/2 LOAD	STG.T % FLT	STG.C % FLC			
0.37	0.50	6	ND80	910	1.10	0.40	69.4	69.4	67.4	0.71	0.63	0.52	210	400	250	0.011	17
			ND90S	680	1.40	0.53	66.8	66.8	64.8	0.57	0.50	0.40	170	400	220	0.015	22
0.55	0.75	4	ND80	1410	1.40	0.38	74.0	74.0	72.0	0.73	0.67	0.54	200	500	250	0.007	17
			ND80	910	1.60	0.59	72.0	72.0	70.0	0.71	0.63	0.52	200	400	260	0.011	17
			ND90L	680	1.80	0.79	71.1	71.1	69.1	0.63	0.54	0.45	150	400	200	0.021	22
0.75	1.00	2	ND80	2820	1.70	0.26	77.0	77.0	75.0	0.81	0.73	0.62	250	600	300	0.003	17
			ND80	1410	1.70	0.52	82.5	82.5	80.5	0.78	0.75	0.64	200	500	250	0.007	17
			ND90S	935	2.00	0.78	74.6	74.6	72.6	0.72	0.65	0.58	200	400	250	0.015	22
			ND100L	700	2.60	1.04	73.8	73.8	71.8	0.58	0.51	0.41	175	400	225	0.030	32
1.10	1.50	2	ND80	2820	2.40	0.38	82.8	82.8	80.8	0.82	0.77	0.70	225	600	275	0.004	17
			ND90S	1415	2.50	0.76	83.8	83.8	81.8	0.78	0.75	0.64	200	500	250	0.014	22
			ND90L	935	2.80	1.15	77.3	77.3	75.3	0.72	0.66	0.58	200	500	250	0.021	25
			ND100L	700	3.40	1.53	76.2	76.2	74.2	0.63	0.54	0.44	175	400	225	0.034	35
1.50	2.00	2	ND90S	2830	3.20	0.52	84.1	84.1	82.1	0.82	0.77	0.70	225	600	275	0.006	22
			ND90L	1415	3.20	1.03	85.0	85.0	83.0	0.81	0.78	0.71	200	600	250	0.019	25
			ND100L	935	3.70	1.56	79.6	79.6	77.6	0.72	0.66	0.58	200	500	250	0.030	32
			ND112M	700	4.00	2.09	77.9	77.9	75.9	0.68	0.60	0.52	190	400	240	0.057	45
2.20	3.00	2	ND90L	2830	4.60	0.76	85.6	85.6	83.6	0.82	0.77	0.70	250	650	300	0.008	25
			ND100L	1440	4.60	1.49	86.4	86.4	84.4	0.82	0.78	0.72	200	600	250	0.030	32
			ND112M	935	5.10	2.29	82.2	82.2	80.2	0.75	0.71	0.63	200	500	250	0.048	45
			ND132S	710	5.40	3.02	80.5	80.5	78.5	0.73	0.68	0.61	180	500	230	0.174	68
3.70	5.00	2	ND100L	2840	7.20	1.27	87.5	87.5	85.5	0.85	0.81	0.73	250	650	300	0.022	36
			ND112M	1430	7.40	2.52	88.3	88.3	86.3	0.82	0.78	0.72	200	600	250	0.052	45
			ND132S	950	7.70	3.79	85.1	85.1	83.1	0.79	0.73	0.63	200	600	250	0.174	68
5.50	7.50	2	ND132S	2865	10.50	1.87	88.6	88.6	86.6	0.85	0.82	0.76	200	600	300	0.034	42
			ND132S	1450	10.10	3.69	89.2	89.2	87.2	0.88	0.85	0.75	225	600	275	0.131	68
			ND132M	950	11.30	5.64	86.8	86.8	84.8	0.80	0.75	0.68	200	600	250	0.214	79
7.50	10.00	2	ND132S	2880	13.30	2.54	89.5	89.5	87.5	0.89	0.85	0.80	250	650	300	0.062	68
			ND132M	1455	13.60	5.02	90.1	90.1	88.1	0.88	0.85	0.75	225	650	275	0.161	79
3.70	5.00	8	ND160M	710	8.0	5.08	83.0	83.0	81.0	0.74	0.70	0.62	150	700	225	0.46	120
5.50	7.5	8	ND160M	710	12.0	7.55	85.1	85.1	83.1	0.74	0.70	0.62	150	700	225	0.46	120
7.50	10.00	6	ND160M	975	11.0	5.49	88.1	88.1	86.1	0.80	0.76	0.68	200	700	250	0.46	120
			ND160L	710	12.0	7.55	86.4	86.4	84.4	0.76	0.72	0.64	150	700	225	0.64	146
9.3	12.5	2	ND160M	2920	17.0	3.10	90.0	90.0	88.0	0.88	0.86	0.78	250	700	300	0.13	125
			ND160M	1460	17.0	6.20	90.5	90.5	88.5	0.84	0.81	0.73	175	700	225	0.31	125
			ND160L	975	18.0	9.29	89.3	89.3	87.3	0.80	0.76	0.68	200	700	250	0.59	148
			ND180M	720	20.0	12.58	87.3	87.3	85.3	0.74	0.70	0.60	175	700	225	0.99	174
11	15	2	ND160M	2920	20.0	3.67	90.5	90.5	88.5	0.88	0.86	0.78	250	700	300	0.13	120
			ND160M	1460	21.0	7.34	91.0	91.0	89.0	0.82	0.79	0.70	200	700	250	0.36	120
			ND160L	975	22.0	10.99	89.7	89.7	87.7	0.80	0.76	0.68	200	700	250	0.64	146
			ND180L	720	24.0	14.88	88.1	88.1	86.1	0.74	0.70	0.60	175	700	225	1.16	205
15	20	2	ND160M	2920	26.0	5.00	91.3	91.3	89.3	0.88	0.86	0.79	250	700	300	0.17	120
			ND160L	1460	27.0	10.01	91.8	91.8	89.8	0.85	0.83	0.75	200	700	250	0.47	146
			ND180L	975	29.0	14.98	90.5	90.5	88.5	0.79	0.73	0.66	225	700	275	1.16	205
			ND200L	725	33.0	20.15	89.0	89.0	87.0	0.71	0.65	0.55	225	700	275	2.14	270



EFF Level 1

PERFORMANCE FIGURES OF TEFC SCR MOTORS FOR 50°/70°- EFF LEVEL 1

OUTPUT		P O L E	FRAME SIZE	FL RPM	FLC AMPS.	FLT Kg-m	EFFICIENCY (%)			POWER FACTOR			DOL STG.		POT % FLT	GD. ² KGM. ²	NET WT. KG
KW	HP						FL	3/4 LOAD	1/2 LOAD	FL	3/4 LOAD	1/2 LOAD	STG.T % FLT	STG.C % FLC			
18.5	25	2	ND160L	2920	32.0	6.17	91.8	91.8	89.8	0.88	0.86	0.79	250	700	300	0.21	146
		4	ND180M	1475	34.0	12.22	92.2	92.2	90.2	0.84	0.80	0.72	200	700	250	0.81	170
		6	ND200L	975	34.0	18.48	91.3	91.3	89.3	0.84	0.80	0.70	200	700	250	1.69	270
		8	ND225S	725	39.0	24.85	89.8	89.8	87.8	0.75	0.71	0.63	175	700	225	3.24	345
22	30	2	ND180M	2940	40.0	7.29	92.2	92.2	90.2	0.84	0.80	0.74	175	700	225	0.44	164
		4	ND180L	1475	40.0	14.53	92.6	92.6	90.6	0.84	0.80	0.72	200	700	250	0.95	205
		6	ND200L	975	40.0	21.98	91.8	91.8	89.8	0.84	0.80	0.70	200	700	250	2.04	270
		8	ND225M	725	46.0	29.56	90.2	90.2	88.2	0.75	0.71	0.63	175	700	225	3.61	375
30	40	2	ND200L	2950	52.0	9.91	92.9	92.9	90.9	0.87	0.84	0.80	200	700	250	0.80	270
		4	ND200L	1475	53.0	19.81	93.2	93.2	91.2	0.86	0.82	0.76	225	700	275	1.62	270
		6	ND225M	980	53.0	29.82	92.6	92.6	90.6	0.85	0.81	0.72	200	700	250	3.61	375
		8	ND250M	735	61.0	39.76	91.5	91.5	89.5	0.75	0.71	0.63	175	700	225	4.82	465
37	50	2	ND200L	2950	64.0	12.22	93.3	93.3	91.3	0.87	0.84	0.80	200	700	250	0.89	270
		4	ND225S	1475	63.0	24.43	93.6	93.6	91.6	0.89	0.86	0.78	250	700	300	2.64	345
		6	ND250M	980	66.0	36.77	93.0	93.0	91.0	0.84	0.80	0.72	225	700	275	4.82	465
		8	ND280S	735	75.0	49.03	91.9	91.9	89.9	0.75	0.71	0.63	200	700	250	8.01	600
45	60	2	ND225M	2955	72.0	14.83	93.7	93.7	91.7	0.94	0.92	0.88	225	700	275	1.87	375
		4	ND225M	1475	76.0	29.72	93.9	93.9	91.9	0.89	0.86	0.78	250	700	300	3.13	375
		6	ND280S	980	79.0	44.72	93.4	93.4	91.4	0.85	0.81	0.73	225	700	275	8.01	600
		8	ND280M	725	91.0	60.46	92.4	92.4	90.4	0.75	0.71	0.63	175	700	225	9.89	630
55	75	2	ND250M	2955	87.0	18.13	94.0	94.0	92.0	0.94	0.92	0.88	175	700	225	2.79	465
		4	ND250M	1475	92.0	36.32	94.2	94.2	92.2	0.89	0.86	0.82	200	700	250	3.45	465
		6	ND280M	980	95.0	54.66	93.8	93.8	91.8	0.86	0.82	0.74	200	700	250	9.89	630
		8	ND315S	740	113.0	72.39	93.0	93.0	91.0	0.73	0.66	0.56	200	700	250	14.12	900
75.0	100.0	2	ND280S	2975	124.0	24.55	94.6	94.6	92.6	0.90	0.86	0.78	225	700	275	7.14	600
		4	ND280S	1480	123.0	49.36	94.7	94.7	92.7	0.90	0.88	0.82	200	700	250	7.21	600
		6	ND315S	987	134.0	74.01	94.2	94.2	92.2	0.83	0.76	0.64	200	700	250	14.12	900
		8	ND315M	740	153.0	98.72	93.5	93.5	91.5	0.73	0.66	0.56	200	700	250	18.98	950
90	120	2	ND280M	2975	148.0	29.46	95.0	95.0	93.0	0.90	0.86	0.78	225	700	275	8.18	630
		4	ND280M	1480	147.0	59.21	95.0	95.0	93.0	0.90	0.88	0.82	225	700	275	8.26	630
		6	ND315M	987	156.0	88.79	94.5	94.5	92.5	0.85	0.80	0.70	200	700	250	17.00	950
		8	ND315L	740	180.0	118.43	94.0	94.0	92.0	0.74	0.70	0.60	150	700	225	29.85	1160
110	150	2	ND315S	2965	173.0	36.13	95.0	95.0	93.0	0.94	0.90	0.82	175	700	225	6.63	900
		4	ND315S	1485	176.0	72.13	95.2	95.2	93.2	0.92	0.88	0.80	225	700	275	11.62	900
		6	ND315M	987	188.0	108.52	94.6	94.6	92.6	0.86	0.82	0.74	200	700	250	18.98	950
		8	ND315L	740	220.0	144.75	94.3	94.3	92.3	0.74	0.70	0.60	150	700	225	29.85	1160
132	180	2	ND315M	2965	207.0	43.35	95.3	95.3	93.3	0.94	0.90	0.82	175	700	225	7.97	950
		4	ND315M	1490	225.0	86.26	95.5	95.5	93.5	0.86	0.82	0.74	225	700	275	13.98	950
		6	ND315L	990	225.0	129.83	94.9	94.9	92.9	0.86	0.82	0.74	200	700	250	29.85	1160
		8	ND315LX	740	263.0	173.70	94.7	94.7	92.7	0.74	0.70	0.60	150	700	225	29.85	1160
160	215	2	ND315L	2975	249.0	52.37	95.5	95.5	93.5	0.94	0.92	0.90	175	700	225	16.37	1130
		4	ND315L	1488	260.0	104.70	95.8	95.8	93.8	0.90	0.86	0.78	175	700	225	24.97	1160
		6	ND315LX	990	272.0	157.37	95.1	95.1	93.1	0.86	0.82	0.74	200	700	225	29.85	1160

NOTE : FOR HIGHER EFFICIENCY FIGURES REFER TO THE DIVISION

Flame Proof Motors



0.18 kW to 335 kW
From 80 to 355 Frame



FLP Motors

THE WIDEST AVAILABLE RANGE

SQUIRREL CAGE MOTORS

0.37 kw to 355 kw (Frames E 80 to E 355 LX)

SLIP RING MOTORS

22 kw to 160 kw
(Frames EW 250 M to EW 315 L)

STANDARD SPECIFICATIONS

- **VOLTAGE** : 415 ± 10%
Other Voltage class (220 V - 660 V) available on request.
- **FREQUENCY** : 50 ± 5%
25 HZ to 60 HZ available on request.
- Combined variation : ± 10 % (absolute sum)
- **INSULATION** : Class F
Class 'H' can be given on request.
- **RATING/DUTY** : Continuous (S1)
Intermittent duties available on request.
- **MOUNTING** : Horizontal foot mounting (B3)
Other mountings available on request.
- **PAINT** : Epoxy anticorrosive painted surface
(Standard shade 631 as per IS - 5)
- **AMBIENT / TEMPERATURE RISE** :
45°C/75°C. Higher Amb. upto 60°C on request.
- **TEMPERATURE CLASS** : T4
- **DEGREE OF PROTECTION** :
IP 54 - E80 - E132 M
E225 M to E355 LX
(IP55 with canopy can be offered.)
IP55 - Frame E 160L to E 200 L.
- CMRI/DGMS approvals as a standard feature.
For BASEEFA approval please contact nearest branch office/works.

APPLICABLE STANDARDS

Enclosure -	IS 2148 EN 50018
Performance -	IS325 BS 5000 (Part 10) IEC60034 -1
Performance for Mines	IS 3682
Dimensions - Foot -	IS 1231 IEC60072-1
Flange -	IS2223 BS4999 Part 414

INDUSTRIAL APPLICATIONS

- Coal Mines.
- Petro Chemicals & Chemicals.
- Oil Mines & Rigs.
- Fertilizers.
- Solvent extraction plants.
- Paints & Varnish Industry.
- LPG Bottling plants.
- Agro Chemicals.
- Drugs & Pharmaceuticals.
- General Industry.

SPECIAL PURPOSE MOTORS FOR

1. Longwall mining equipment.
2. High pressure mine ventilation fans with plug & socket arrangement.
3. Auxiliary mine ventilation fans with rod mounting / flange mounting.
4. Belt conveyors and armoured face/ chain conveyors.
5. Side dump loaders, load haul dumpers
6. Haulages (squirrel cage and slipring motors).
7. Dewatering pumps.
8. Sucker rod pumps.
9. Mud agitators & mud pumps.
10. Slurry extraction pumps.
11. Air compressors & blowers.

SPECIAL DESIGN FEATURES AVAILABLE

1. Dual voltage (550/1100V) with 9 terminal connections as per NCB 625
2. Non standard voltage and frequency variation
3. Dual voltage (1:2 or 1: $\sqrt{3}$ ratio)
Tripple voltage (1: $\sqrt{3}$: 2 ratio)
4. Energy efficient motors
High slip motors
Motors for frequent starts/stops/reversals
5. 10,12,16,18,24,32 pole motors
6. Special performance requirements
7. Class H insulated motors
8. Low vibration and noise level



FLP Motors

9. Special Bearings
10. Tacho mounting
11. Special shaft material
12. Canopy
13. Plug & socket arrangement (30 to 300 Amps, 650 & 1100V) for underground equipments.
14. Flange/foot cum flange /rod mounting.
15. Special RV/RA for slipring motors.
16. Space heaters, thermisters.
17. Multispeed motors.
18. Double /taper/non standard shaft extention
19. Non standard paint shade
20. Motors for use with variable frequency inverter supply

TERMINAL BOX AND TERMINAL ARRANGEMENT

- Cast iron construction, forming a separate flame proof enclosure capable of containing internal explosions.
- Standard position on right hand side viewed from driving end side except in frames E 80, E/EW 315 L & E 355 LX where it is on top.
- Terminal box on top on specific request.
- New terminal box with spigotted cover & gland plate/sealing box in frames E 160 to 355 LX with following advantages.
 - Inherently IP 55.
 - Spaciously designed for accommodating bigger cables.
 - Double decker terminal arrangement for easy termination of two cables.
 - Anti loosening terminal arrangement
- For slipring motors, separate terminal box for stator & rotor terminations provided. Stator terminal box is on left hand side while rotor terminal box is on right hand side, viewed from driving end.
- Conduit plate is provided as standard while sealing box provided for group I gases.

- Separate terminal box for auxiliary terminals (space heaters, thermisters) for frame 225 and above on request.

TERMINAL STUD

- Fully non hygroscopic thermosetting moulded glass filled compound.
- Increased clearances & creepages.
- Anti loosening arrangement.
- Metallic bush insert to take tightening pressure. Eliminates breakage of insulation (E160-315LX frames)

BEARING CHART

FRAME	DE	NDE
E80	6304-2Z	6304-2Z
E90	6205-2Z	6205-2Z
E100	6206-2Z	6206-2Z
E112	6306-2Z	6306-2Z
E132	6308-2Z	6208-2Z
E160	6309-2RS	6309-2RS
E180	6310-2RS	6310-2RS
E200	6312-2RS	6312-2RS
E225	6313-2RS	6313-2RS
E250-2P	6315	6315
E/EW250-4P UP	6315	6315
E280-2P	6315	6315
E/EW280-4P UP	6318	6318
E315-2P	6315	6315
E/EW315-4P UP	6319	6319



FLP Motors

STATUTORY APPROVALS

COUNTRY	STATUTORY AUTHORITY	FLAME PROOF NOTATION / MARK	
	SCOPE		
INDIA	CMRI DHANBAD		STANDARD
	TESTING		
	ERTL KOLKATA		
	TESTING		
	DGMS DHANBAD		
	APPROVING		
	CCE NAGPUR		
	APPROVING		
	DGFAS & LI MUMBAI		
	APPROVING		
	BIS		OPTIONAL Requirement to be specified at the time of enquiry / order
	LICENCE		
UK. ①	BASEEFA		
	CERTIFICATE & LICENCE		
	ATEX CE MARK	CE 1180 Ex II 2 G EEx d IIB T4*	
	LICENCE		

FLAMEPROOF MOTORS FOR GROUP IIC ATMOSPHERE

A complete range of Crompton Greaves flameproof squirrel cage motors for gas group IIC is now available for Indian Industries as an import substitute. The motors are manufactured as per the most stringent requirements for IIC atmosphere. The motors are duly tested at CMRI, Dhanbad.

For more details, please contact our nearest branch office / works.

	CMRI	ERTL	DGMS	CCE	DGFAS & LI	GROUP SUITABILITY
E 80	√	√	—	√	√	IIA, IIB ONLY
E 90L	√	√	√	√	√	I, II A, II B.
E100L E112 M, E 132 M.	√	√	√	√	√	I, IIA, IIB
E160L, E 180 L, E200 L	√	√	√	√	√	I, IIA, IIB
E225 S, E 225 M E250 M	√	√	√	√	√	I, II A, IIB.
E280 M E315 M/L	√	√	√	√	√	I, IIA, IIB.

BASEEFA*	
ATEX	IECEX'd'
√	---
√	---
√	√
√	√
√	√
√	√

√ AVAILABLE Δ Pending for approval.

* STANDARD Temperature class T4. Other classes available on request.

* For IIA, IIB Gas Groups

CMRI	: CENTRAL MINING RESEARCH INSTITUTE, DHANBAD.
DGMS	: DIRECTORATE GENERAL OF MINES SAFETY, DHANBAD.
CCE	: CHIEF CONTROLLER OF EXPLOSIVES, NAGPUR.
DGFAS & LI	: DIRECTORATE GENERAL FACTORY ADVICE SERVICE & LABOUR INSTITUTE, MUMBAI.
BIS	: BUREAU OF INDIAN STANDARDS, NEW DELHI.
BASEEFA	: BRITISH APPROVALS SERVICE FOR ELECTRICAL EQUIPMENT IN FLAMMABLE ATMOSPHERES, UK.
ATEX	: EUROPEAN DIRECTIVE
ERTL	: ELECTRONIC REGIONAL TEST LABORATORY

NOTE:* Motors as per UK based standards can be supplied against specific enquiries.



FLP Motors

CABLE TERMINATION

CABLE SIZE REFERENCE CHART

FRAME SIZE	MAX. CABLE SIZE				TERMINAL STUD			
	GROUP I - COPPER inch ²		GROUP II - AL. mm ²		MAIN		EARTH	AUX.
	DOL	STAR/DELTA	DOL	STAR/DELTA	NOS.	SIZE	SIZE	SIZE
E 80	NA	NA	4	NA	3	M6	M6	NA
E 90L TO E 132 M	0.25	2 X 0.06	10	2 X 6	6	M6	M6	NA
					3	M6		M6
E 160L TO E 200 L	0.25	2 X 0.06	50 (95 WITH ADAPTOR)	2 X 50	6	M8	M8	M6
E225S TO E315M	0.25	2 X 0.25	185	2 X 185	6	M10	M8	M6
E 315 L	0.25	2X0.25 Double Sealing Box 2X0.06 Single Sealing Box	240	2 x 240 Double Sealing Box 2 x 120 Single Sealing Box	6	M14	M8	M8
					3	M16		
EW250 M STATOR ROTOR	0.25	NA	185 95	NA	3	M10	M8	M6
					3	M8		
EW280-EW 315 M STATOR ROTOR	0.25	NA	185 185	NA	3	M10	M8	M6
					3	M10		
EW 315 L STATOR ROTOR	0.25	NA	240 185	NA	3	M16	M8	M8
					3	M10		

NA -Not Available

Note : Motors upto & including 2.2 kw are with 3 leads. 3.7 kw & above are with 6 leads.

Following alternative methods of electrical connections/ cable entry can be provided:

1. CMRI approved double compression glands.
2. For group I areas, cable clamps for single/double armoured cable with single/double cone arrangement.
3. Plug and socket arrangement (suitable for 1100 or 650 V) for PATC cables for group I areas. (E 160 L- E 355 LX)
4. Sealing box with entry thread for solid drawn conduit arrangement.

SHIPPING SPECIFICATIONS

FOOT MOUNTING MOTORS					FLANGE MOUNTING MOTORS				
FRAME SIZE	NET WT. KG	GROSS WT. KG	DIMENSIONS LxBxH mm	VOL. CU.M.	FRAME SIZE	NET WT. KG	GROSS WT. KG	DIMENSIONS LxBxH mm	VOL. CU.M.
E80	23	27	345 X 220 X 335	0.025	E80	25	30	345 X 220 X 335	0.025
E90L	40	56	467 X 477 X 319	0.071	E90L	42	70	528 X 362 X 672	0.128
E100L	54	74	507 X 507 X 368	0.095	E100L	56	89	582 X 422 X 687	0.169
E112M	73	102	590 X 532 X 427	0.134	E112M	76	109	582 X 422 X 687	0.169
E132M	110	143	622 X 575 X 427	0.153	E132M	113	156	628 X 472 X 732	0.216
E160L	188	259	875 X 705 X 427	0.36	E160L	215	333	960 X 815 X 815	0.64
E180L	256	362	1025 X 825 X 700	0.59	E180L	260	378	960 X 815 X 815	0.64
E200L	263	369	1025 X 825 X 700	0.59	E200L	300	442	1065 X 885 X 840	0.79
E225S	330	382	1150 X 845 X 710	0.69	E225S	365	510	1065 X 885 X 840	0.79
E225M	400	449	1150 X 845 X 710	0.69	E225M	435	577	1065 X 885 X 840	0.79
E250M	680	818	1300 X 915 X 745	0.89	E250M	705	935	990 X 900 X 1245	1.11
E280M	966	1180	1500 X 1065 X 850	1.36	E280M	1000	1270	1070 X 1070 X 1430	1.64
E315M	1136	1389	1600 X 1170 X 925	1.73	E315M	1180	1508	1280 X 1210 X 1545	2.39
E315L	1752	2105	1830 X 1270 X 1156	2.69	E315L	1800	2214	1850 X 1450 X 1275	3.42
EW250M	740	1015	1730 X 1170 X 865	1.75	EW250M	-	-	-	-
EW280M	1105	1460	2160 X 1220 X 1010	2.66	EW280M	-	-	-	-
EW315M	1300	1645	2160 X 1220 X 1010	2.66	EW315M	-	-	-	-
EW315L	1900	2430	2565 X 1245 X 1120	3.58	EW315L	-	-	-	-



FLP Motors

PERFORMANCE FIGURES OF FLP SCR MOTORS FOR 45 AMBIENT 75 DEGREE RISE

OUTPUT		P O L E	FRAME SIZE	FL RPM	FLC AMPS.	EFFICIENCY			POWER FACTOR			DOL STG.		GD SQ. KGM. ²	NET WT KG
KW	HP					FL	3/4 LOAD	1/2 LOAD	FL	3/4 LOAD	1/2 LOAD	STG.T %FLT	STG.C %FLC		
0.18	0.25	2	E80	2850	0.47	68.0	64.0	57.0	0.79	0.72	0.61	250	650	0.003	23
		4	E80	1400	0.51	70.0	66.0	59.0	0.70	0.64	0.58	200	500	0.007	23
		6	E80	950	0.70	58.0	50.0	40.0	0.62	0.52	0.40	220	450	0.011	23
		8	E90L	680	0.73	60.0	56.0	48.0	0.57	0.50	0.40	180	400	0.024	35
0.25	0.33	2	E80	2850	0.65	68.0	64.0	57.0	0.79	0.72	0.61	250	600	0.003	23
		4	E80	1395	0.71	70.0	66.0	59.0	0.70	0.64	0.58	200	500	0.007	23
		6	E80	930	0.93	60.0	54.0	47.0	0.62	0.52	0.40	200	400	0.011	23
		8	E90L	670	1.02	60.0	56.0	48.0	0.57	0.50	0.40	180	400	0.024	38
0.37	0.50	2	E80	2820	0.87	72.0	71.0	65.0	0.82	0.76	0.68	225	550	0.003	23
		4	E80	1410	0.95	73.5	72.5	69.5	0.74	0.7	0.66	225	500	0.007	23
		6	E80	910	1.05	69.0	68.0	66.0	0.71	0.63	0.52	210	400	0.011	23
		8	E90L	680	1.34	64.0	63.5	62.0	0.6	0.53	0.48	175	400	0.024	35
0.55	0.75	2	E80	2820	1.29	73.0	72.0	68.0	0.81	0.73	0.62	250	600	0.003	23
		4	E80	1410	1.27	77.0	76.0	74.0	0.78	0.75	0.64	200	500	0.007	23
		6	E80	910	1.56	69.0	68.0	66.0	0.71	0.63	0.52	210	400	0.011	23
		8	E90L	685	1.69	72.0	71.0	68.0	0.63	0.55	0.45	175	400	0.034	38
0.75	1.00	2	E80	2820	1.59	77.0	76.0	73.0	0.85	0.8	0.72	250	600	0.003	23
		4	E80	1410	1.74	77.0	76.0	74.0	0.78	0.75	0.64	200	500	0.007	23
		6	E90L	925	2.07	72.0	72.0	70.0	0.7	0.62	0.52	230	400	0.024	35
		8	E100L	700	2.23	72.0	71.0	68.0	0.65	0.58	0.48	175	400	0.038	49
1.10	1.50	2	E90L	2830	2.31	78.0	76.0	73.0	0.85	0.8	0.72	230	650	0.010	36
		4	E90L	1415	2.62	77.0	76.0	74.0	0.76	0.7	0.62	225	500	0.018	35
		6	E90L	925	3.04	72.0	68.0	64.0	0.70	0.62	0.52	180	500	0.034	38
		8	E100L	700	3.27	72.0	69.0	68.0	0.65	0.58	0.48	175	400	0.050	51
1.50	2.00	2	E90L	2850	3.15	78.5	77.0	73.0	0.85	0.8	0.72	230	600	0.010	36
		4	E90L	1415	3.26	80.0	79.0	77.0	0.8	0.75	0.7	200	550	0.025	38
		6	E100L	945	3.53	80.0	79.0	77.0	0.74	0.65	0.56	200	500	0.038	49
		8	E112M	715	3.82	78.0	77.0	75.0	0.7	0.64	0.55	225	500	0.130	61
2.20	3.00	2	E90L	2850	4.29	82.0	81.0	79.0	0.87	0.83	0.74	250	600	0.014	39
		4	E100L	1430	4.50	82.0	81.0	78.0	0.83	0.78	0.7	225	600	0.040	49
		6	E112M	945	5.10	80.0	79.0	77.0	0.75	0.7	0.6	200	500	0.106	60
		8	E132M	715	5.18	81.0	80.0	78.0	0.73	0.66	0.59	200	400	0.300	93
3.70	5.00	2	E100L	2850	6.96	84.0	83.0	81.0	0.88	0.84	0.75	250	600	0.029	53
		4	E112M	1430	7.85	84.0	81.0	70.0	0.80	0.75	0.69	200	600	0.099	63
		6	E132M	945	7.57	85.0	84.0	82.0	0.8	0.76	0.72	200	500	0.205	94
		8	E132M	700	8.71	81.0	80.0	78.0	0.73	0.66	0.59	200	400	0.340	98
5.50	7.50	2	E112M	2900	10.35	85.7	83.0	81.0	0.88	0.84	0.75	250	650	0.045	64
		4	E132M	1450	10.59	86.0	85.0	84.0	0.84	0.81	0.73	250	600	0.227	93
		6	E132M	945	11.11	85.0	84.0	82.0	0.81	0.77	0.73	200	500	0.330	98
		8	E160L	710	12.00	85.0	85.0	83.0	0.74	0.7	0.62	150	500	0.460	
7.50	10.00	2	E132M	2900	13.95	87.0	84.0	82.0	0.88	0.85	0.8	250	650	0.108	98
		4	E132M	1450	14.44	87.0	85.0	84.0	0.84	0.81	0.73	225	600	0.269	98
		6	E160L	975	11.00	87.5	87.0	85.0	0.8	0.76	0.68	200	550	0.46	260
		8	E160L	710	12.00	85.0	85.0	83.0	0.76	0.72	0.64	150	500	0.64	260
9.3	12.5	2	E160L	2920	17.0	88.0	87.0	85.0	0.88	0.86	0.78	250	650	0.13	260
		4	E160L	1460	17.0	88.5	88.5	86.5	0.84	0.81	0.73	175	600	0.31	260
		6	E160L	975	18.0	87.5	87.0	84.0	0.80	0.76	0.68	200	550	0.59	260
		8	E180L	720	20.0	86.0	86.0	84.0	0.74	0.70	0.60	175	500	0.99	260
11.0	15.0	2	E160L	2920	20.0	88.5	88.0	86.0	0.88	0.86	0.78	250	650	0.13	260
		4	E160L	1460	21.0	89.0	89.0	86.0	0.82	0.79	0.70	200	600	0.36	260
		6	E160L	975	22.0	88.0	87.5	86.0	0.80	0.76	0.68	200	550	0.64	260
		8	E180L	720	24.0	87.0	87.0	85.0	0.74	0.70	0.60	175	500	1.16	285
15.0	20.0	2	E160L	2910	26.0	89.5	89.5	87.5	0.88	0.86	0.79	250	650	0.17	260
		4	E160L	1475	28.0	90.0	90.0	88.0	0.85	0.83	0.75	200	600	0.47	260
		6	E180L	975	28.0	90.0	90.0	88.0	0.79	0.73	0.66	225	600	1.16	285
		8	E200L	735	34.0	88.5	88.5	86.5	0.71	0.65	0.55	225	500	2.14	310



FLP Motors

PERFORMANCE FIGURES OF FLP SCR MOTORS FOR 45 AMBIENT 75 DEGREE RISE

OUTPUT		P O L E	FRAME SIZE	FL RPM	FLC AMPS.	EFFICIENCY			POWER FACTOR			DOL STG.		GD SQ. KGM. ²	NET WT KG
KW	HP					FL	3/4 LOAD	1/2 LOAD	FL	3/4 LOAD	1/2 LOAD	STG.T %FLT	STG.C %FLC		
18.5	25.0	2	E160L	2920	32.0	90.0	90.0	88.0	0.88	0.86	0.79	250	650	0.21	260
		4	E180L	1475	34.0	91.5	91.5	90.0	0.84	0.80	0.72	200	600	0.81	285
		6	E200L	975	34.0	91.1	91.1	89.9	0.84	0.80	0.70	200	550	1.69	310
		8	E225S	725	39.0	89.0	88.5	87.0	0.75	0.71	0.63	175	500	3.30	330
22.0	30.0	2	E180L	2940	40.0	91.0	91.0	89.0	0.84	0.80	0.74	175	600	0.44	285
		4	E180L	1475	40.0	92.0	92.0	90.0	0.84	0.80	0.72	200	600	0.95	285
		6	E200L	975	40.0	91.5	91.5	90.1	0.84	0.80	0.70	200	550	2.04	310
		8	E225M	725	46.0	89.0	88.5	87.0	0.75	0.71	0.63	175	500	3.90	400
30.0	40.0	2	E200L	2950	52.0	91.5	91.0	89.0	0.87	0.84	0.80	200	600	0.80	310
		4	E200L	1475	53.0	92.0	92.0	90.2	0.86	0.82	0.76	225	600	1.62	310
		6	E225M	975	56.0	91.5	91.0	89.5	0.82	0.78	0.70	200	600	3.70	400
		8	E250M	735	63.0	90.5	87.0	88.5	0.73	0.69	0.61	175	550	7.49	680
37.0	50.0	2	E200L	2950	64.0	92.5	92.0	90.0	0.87	0.84	0.80	200	600	0.89	310
		4	E225S	1480	63.0	92.5	92.0	90.5	0.89	0.85	0.77	250	600	2.70	330
		6	E250M	975	65.0	92.0	91.5	90.0	0.86	0.82	0.74	200	600	7.51	680
		8	E280M	740	75.0	91.5	91.0	89.5	0.75	0.71	0.63	225	500	14.15	966
45.0	60.0	2	E225M	2955	73.0	92.5	90.0	88.0	0.94	0.90	0.82	200	650	1.50	400
		4	E225M	1480	76.0	93.0	92.5	91.0	0.89	0.85	0.77	250	600	3.20	400
		6	E280M	990	78.0	93.0	92.5	91.0	0.86	0.82	0.74	225	600	14.15	966
		8	E280M	740	91.0	92.0	91.5	90.0	0.75	0.71	0.63	225	600	14.15	966
55.0	75.0	2	E250M	2980	90.0	93.0	92.0	90.0	0.92	0.88	0.80	200	600	6.22	680
		4	E250M	1475	94.0	93.0	92.5	91.0	0.88	0.84	0.76	225	600	6.26	680
		6	E280M	985	96.0	93.0	92.5	91.0	0.86	0.82	0.74	225	600	14.15	966
		8	E315M	735	110.0	92.0	91.5	90.0	0.76	0.72	0.64	225	550	24.20	1136
75.0	100.0	2	E280M	2975	119.0	93.6	93.0	91.5	0.94	0.90	0.82	175	600	7.25	966
		4	E280M	1488	122.0	93.6	93.0	91.5	0.92	0.88	0.80	225	600	11.60	966
		6	E315M	985	130.0	93.5	93.0	91.5	0.86	0.82	0.74	225	600	24.20	1136
		8	E315M	735	148.0	93.0	92.5	91.0	0.76	0.72	0.64	225	550	24.20	1136
90.0	120.0	2	E280M	2975	142.0	94.0	93.5	92.0	0.94	0.90	0.82	175	600	7.25	966
		4	E280M	1488	145.0	93.9	93.3	91.8	0.92	0.88	0.80	225	600	11.60	966
		6	E315M	985	155.0	93.8	93.3	91.8	0.86	0.82	0.74	225	600	24.20	1136
		8	E315L	740	172.0	93.5	93.0	91.5	0.78	0.74	0.66	250	550	33.33	1752
110.0	150.0	2	E315M	2975	174.0	94.0	93.0	91.5	0.94	0.90	0.82	200	600	10.76	1136
		4	E315M	1485	181.0	94.4	93.5	92.0	0.90	0.86	0.78	200	600	20.30	1136
		6	E315L	985	190.0	94.0	93.5	92.0	0.86	0.82	0.74	225	600	40.00	1752
		8	E315L	740	210.0	93.5	93.0	91.5	0.78	0.74	0.66	250	550	40.00	1752
132.0	180.0	2	E315M	2975	209.0	94.5	93.0	91.5	0.94	0.90	0.82	200	600	10.76	1136
		4	E315M	1485	217.0	94.7	93.5	92.0	0.90	0.86	0.78	200	600	20.30	1136
		6	E315L	985	227.0	94.0	93.5	92.0	0.86	0.82	0.74	250	550	33.33	1752
		8	E355LX	740	263.0	94.5	94.5	92.5	0.74	0.70	0.60	150	500	31.80	2500
160.0	215.0	2	E315L	2975	252.0	94.8	93.5	92.0	0.94	0.90	0.82	175	600	16.37	1752
		4	E315L	1490	262.0	95.0	94.0	92.5	0.90	0.86	0.78	200	600	24.97	1752
		6	E315L	990	274.0	94.5	94.0	92.5	0.86	0.82	0.74	250	600	40.00	1752
		8	E355LX	740	317.0	95.0	94.0	92.0	0.74	0.70	0.60	150	500	36.80	2500
180.0	240.0	2	E315L	2975	280.0	95.0	94.5	92.5	0.94	0.92	0.90	175	600	13.90	1752
		4	E315L	1488	292.0	95.3	95.3	94.0	0.90	0.88	0.84	175	600	21.10	1752
		6	E355LX	990	307.0	95.0	94.5	93.0	0.86	0.82	0.76	200	600	33.50	2500
		8	E355LX	742	340.0	94.5	94.5	92.0	0.78	0.74	0.66	125	400	51.10	2500
200.0	270.0	2	E315L	2975	313.0	94.5	94.0	92.5	0.94	0.90	0.82	200	600	16.37	1752
		4	E315L	1490	327.0	94.5	94.0	92.5	0.90	0.86	0.78	225	600	31.10	1752
		6	E355LX	990	349.0	95.0	94.5	93.0	0.84	0.80	0.70	140	500	29.70	2500
		8	E355LX	742	377.0	94.5	94.5	92.5	0.78	0.74	0.66	125	400	58.10	2500
225.0	300.0	2	E355LX	2975	352.0	95.5	95.5	94.0	0.93	0.90	0.84	200	600	18.40	2500
		4	E355LX	1488	365.0	95.5	95.5	93.5	0.90	0.88	0.84	175	600	28.00	2500
		6	E355LX	990	390.0	95.5	95.0	94.0	0.84	0.80	0.70	140	500	31.70	2500



FLP Motors

PERFORMANCE FIGURES OF FLP SCR MOTORS FOR 45 AMBIENT 75 DEGREE RISE

OUTPUT		P O L E	FRAME SIZE	FL RPM	FLC AMPS.	EFFICIENCY			POWER FACTOR			DOL STG.		GD SQ. KGM. ²	NET WT KG
KW	HP					FL	3/4 LOAD	1/2 LOAD	FL	3/4 LOAD	1/2 LOAD	STG.T %FLT	STG.C %FLC		
250.0	335.0	2	E355LX	2970	387.0	95.5	95.0	93.5	0.94	0.92	0.88	150	600	27.70	2500
		4	E355LX	1485	395.0	95.7	95.7	94.0	0.92	0.88	0.84	150	600	29.60	2500
		6	E355LX	990	434.0	95.5	95.0	94.0	0.84	0.80	0.70	140	500	35.60	2500
275.0	370.0	2	E355LX	2980	435.0	95.5	95.0	93.5	0.92	0.90	0.88	150	600	27.70	2500
		4	E355LX	1485	435.0	95.7	95.7	94.0	0.92	0.88	0.84	150	600	31.60	2500
		6	E355LX	990	477.0	95.5	95.0	94.0	0.84	0.80	0.70	140	500	39.80	2500
315.0	425.0	2	E355LX	2980	499.0	95.5	95.5	94.0	0.92	0.90	0.88	175	650	29.60	2500
		4	E355LX	1490	525.0	96.0	96.0	94.5	0.87	0.83	0.73	150	600	35.50	2500
335.0	452.0	2	E355LX	2980	530.0	95.5	95.5	94.0	0.92	0.90	0.88	150	600	29.60	2500
		4	E355LX	1490	558.0	96.0	96.0	94.5	0.87	0.83	0.73	150	600	39.70	2500

NOTE : 1) EFFICIENCY FIGURES ARE AS PER EFF2 CLASS OF IS 12612 - 2004
 2) ALL PERFORMANCE FIGURES ARE SUBJECT TO TOLERANCE AS PER IS 325 - 1996
 FL = Full Load; FLC = Full Load Current; FLT = Full Load Torque
 SGT. T = Starting Torque; SGT. C = Starting Current



FLP Motors

OUTLINE DIMENSION DRAWING FOR 3 PHASE SQUIRREL CAGE TEFC TB ON TOP FOOT MOUNTED FLAME PROOF INDUCTION MOTOR. (FRAME :- E80)

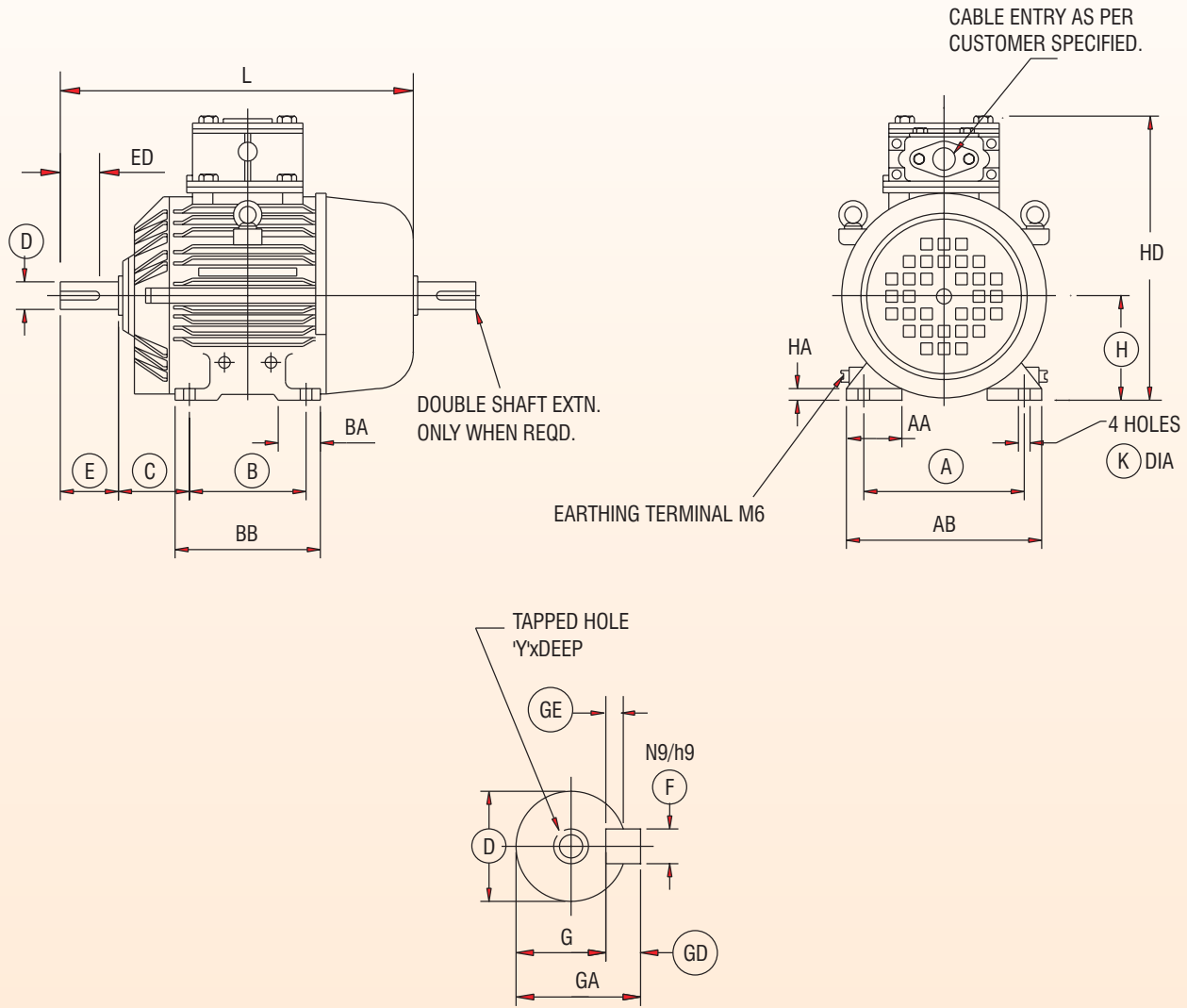

FRAME	FOOT FIXING									SHAFT AND KEY							YxDEEP	OVERALL (MAX)				
	A	B	C	H	AA	AB	BA	BB	K	D	E	ED	F	G	GA	GD		GE	AC	L	HD	HA
E80	125	100	50	80	28	152	25	124	10	19	40	27	6	15.5	21.5	6	3.5	M6x16	165	274	268	11



FLP Motors

OUTLINE DIMENSION DRAWING FOR 3 PHASE SQUIRREL CAGE TEFC FOOT MOUNTED FLAME PROOF INDUCTION MOTORS (4 POLE & UP FOR ALL FRAMES & 2 POLE & UP, UP TO ND200L FRAME.)

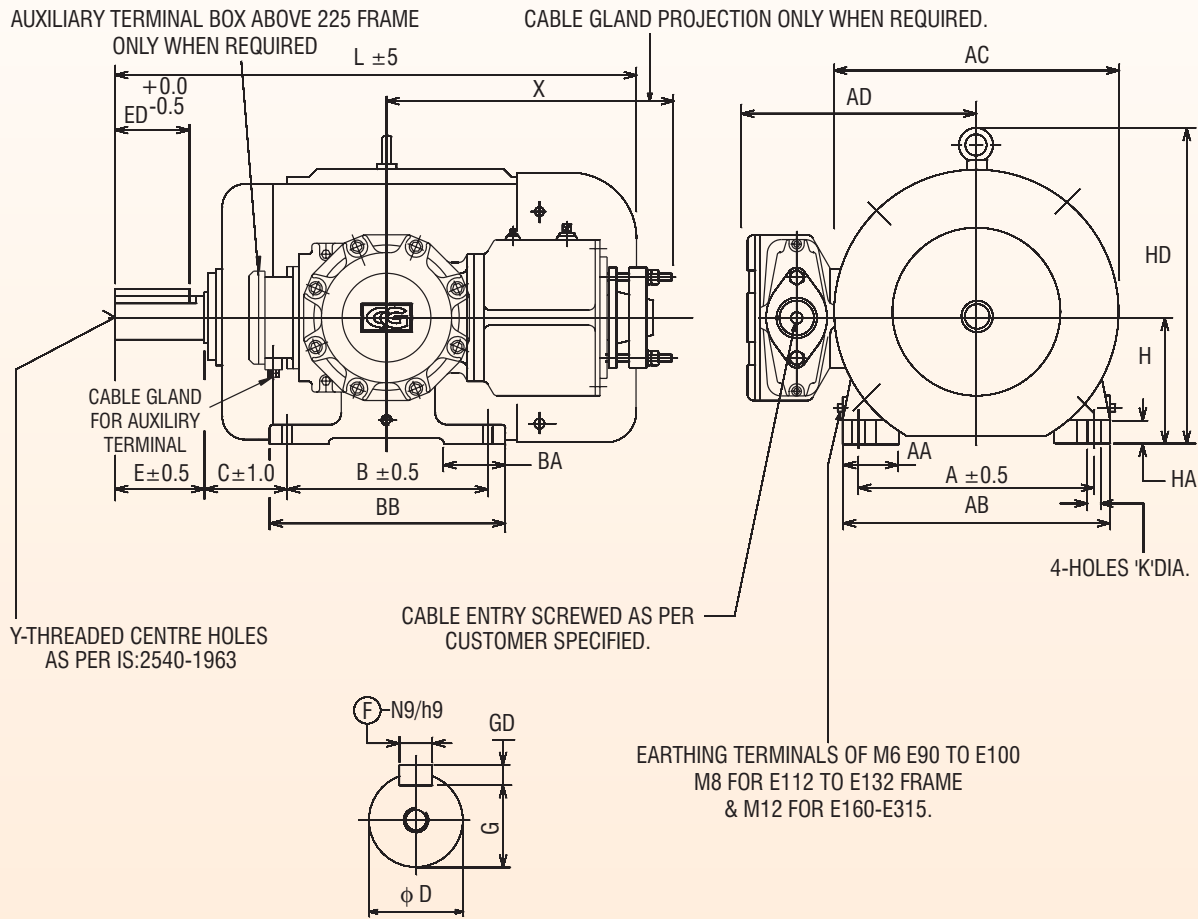

ALL DIMENSIONS ARE IN mm.

FRAME	FOOT FIXING									SHAFT AND KEY *							OVERALL						
	A	B	C	H TOL.	AA	AB	BA	BB	K TOL.	D TOL.	E	ED	F TOL.	GD TOL.	G	Y	AD	AC	L	L Canopy	HD	HA	X
E90L	140	100 125	56	90.0 89.5	35	168	45	152	10.0 9.5	24.030 24.011	50	36	8.00 7.957	7.0 6.91	20.0 19.8	M8x19	240	195	340	--	240	13	-
E100L	160	140	63	100.0 99.5	38	198	51	168	12.0 11.5	28.030 28.011	60	44	8.00 7.957	7.0 6.91	24.0 23.8	M10x22	255	215	380	--	265	13	-
E112M	190	140	70	112.0 111.5	38	228	57	171	12.0 11.5	28.030 28.011	60	44	8.00 7.957	7.0 6.91	24.0 23.8	M10x22	265	235	405	--	290	14	-
E132M	216	178	89	132.0 131.5	41	254	64	216	12.0 11.5	38.030 38.011	80	60	10.0 9.957	8.0 7.91	33.0 32.8	M12x28	268	260	515	--	440	16	-
E160M E160L	254	210 254	108	160.0 159.7	54	298	101	298	15.5 15.0	42.018 42.002	110	80	12.0 11.957	8.00 7.91	37.0 36.8	M16x32	345	320	655	705	376	22	409
E180M E180L	279	241 279	121	180.0 179.7	60	337	107	323	15.5 15.0	48.018 48.002	110	80	14.000 13.957	9.00 8.91	42.5 42.3	M16x32	362	370	750	810	418	22	
E200L	318	305	133	200.0 199.5	64	381	105	356	19.5 19.0	55.030 55.011	110	80	16.0 15.957	10.00 9.91	49.0 48.8	M16x32	400	435	790	875	480	25	
E225S E225M	356	286 311	149	225.0 224.5	70	425	114	349 375	19.5 19.0	60.030 60.011	140	110	18.0 17.957	11.00 10.91	53.0 52.8		402	490	832 857	905 930	525	25	443
E250S E250M	406	311 349	168	250.0 249.5	90	483	160	381 419	24.5 24.0	65.030 65.011	140	110	18.0 17.957	11.00 10.91	58.0 57.8	M20x40	440	560	940 977	1020 1055	605	32	
E280S E280M	457	368 419	190	280.0 279.0	95	540	155	489	24.5 24.0	75.030 75.011	140	110	20.0 19.948	12.00 11.91	67.5 67.3	M20x40	476	620	1094	1215	660	35	
E315M	508	457	216	315.0 314.0	100	597	190	533	28.5 28.0	80.030 80.011	170	140	22.0 21.948	14.00 13.91	71.0 70.8		516	705	1218	1330	775	38	



FLP Motors

OUTLINE DIMENSION DRAWING FOR 3 PHASE SQUIRREL CAGE TEFC FOOT MOUNTED FLAME PROOF INDUCTION MOTORS. (FOR 2 POLE)

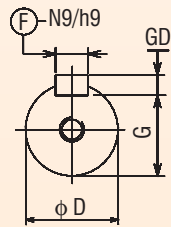
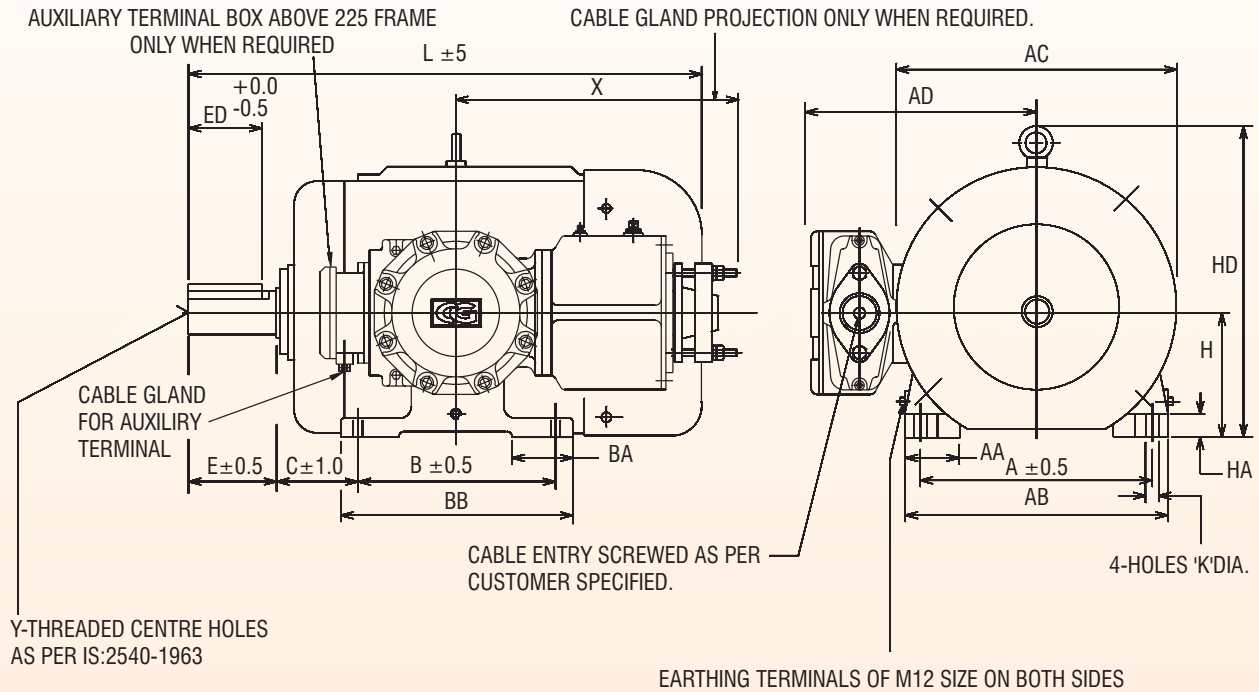

ALL DIMENSIONS ARE IN mm.

FRAME SIZE	FOOT FIXING									SHAFT AND KEY *							OVERALL						
	A	B	C	H TOL.	AA	AB	BA	BB	K TOL.	D	E	ED	F TOL.	GD TOL.	G	Y	AD	AC	L	L Canopy	HD	HA	X
E225S	356	286	149	225.0	70	425	114	349	19.5	55.030	110	80	16.0	10.0	49.0		402	490	802	875	525	25	
E225M		311		224.5				375	19.0				55.011	15.957	9.91				48.8	827			
E250S	406	311	168	250.0	90	483	160	381	24.5	60.030	140	110	18.0	11.00	53.0	M20x40	440	560	940	1020	605	32	443
E250M		349		249.5				419	24.0				60.011	17.957	10.91				52.8	977			
E280S	457	368	190	280.0	95	540	155	489	24.5	65.030	140	110	18.0	11.0	58.0		476	620	1094	1215	660	35	
E280M		419		279.0				24.0	65.011				17.957	10.91	57.8								
E315M	508	457	216	315.0 314.0	100	597	190	533	28.5 28.0	65.030 65.011	140	110	18.0 17.957	11.0 10.91	58.0 57.8		516	705	1188	1300	775	38	



FLP Motors

OUTLINE DIMENSION DRAWING FOR 3 PHASE SQUIRREL CAGE TEFC FOOT MOUNTED FLAME PROOF INDUCTION MOTOR (FRAME: E315L)

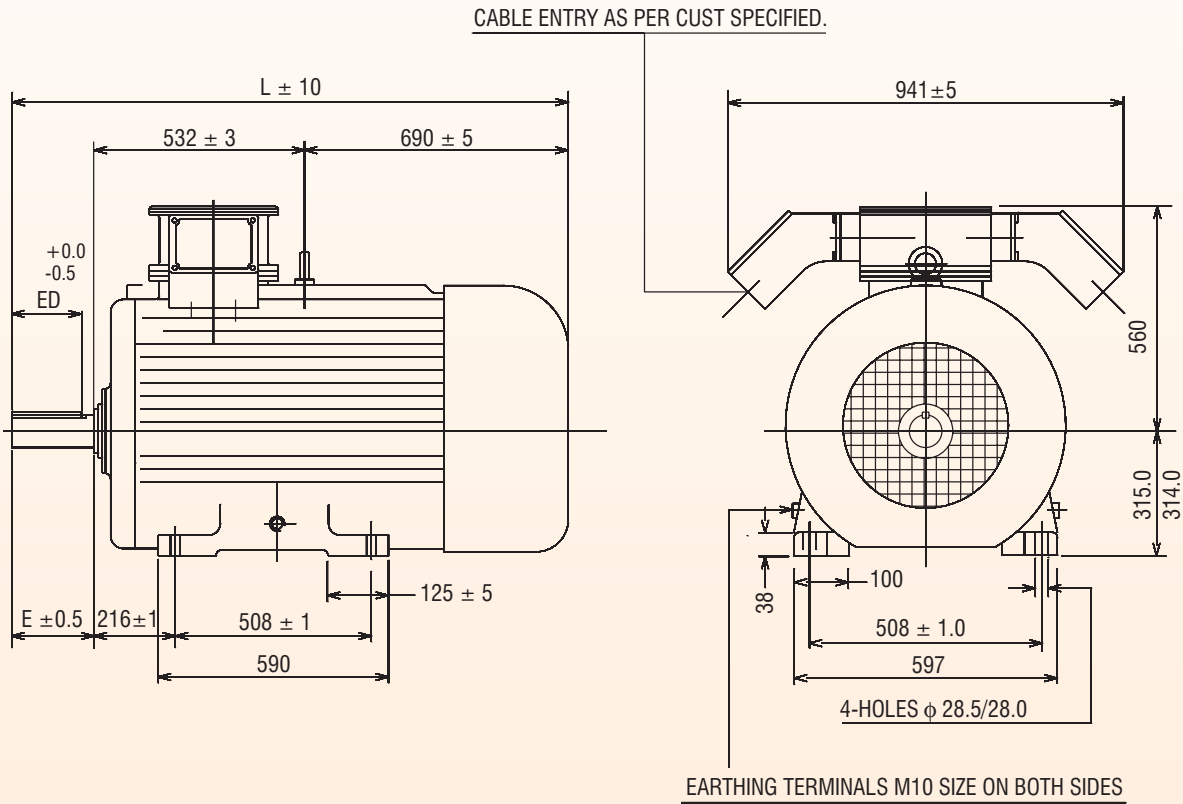

'Y' THREADED CENTRE HOLE
AS PER IS:2540-1963

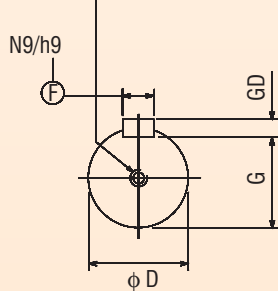

* CABLE ENTRY POSSIBLE FROM EITHER SIDE OF MOTOR

ALL DIMENSIONS ARE IN mm

POLE	SHAFT AND KEY							
	D TOL.	E	ED	F TOL.	GD TOL.	G	Y	L ± 10
4P & UP	90.035/90.013	170	140	25.0/24.948	14.0/13.91	81.0/80.8	M24x50	1392
2	70.030/70.011	140	110	20.0/19.948	12.0/11.91	62.5/62.3	M20x40	1362



FLP Motors

OUTLINE DIMENSION DRAWING FOR 3 PHASE SQUIRREL CAGE TEFC FLANGE MOUNTED FLAME PROOF INDUCTION MOTOR. (FRAME :- E80)

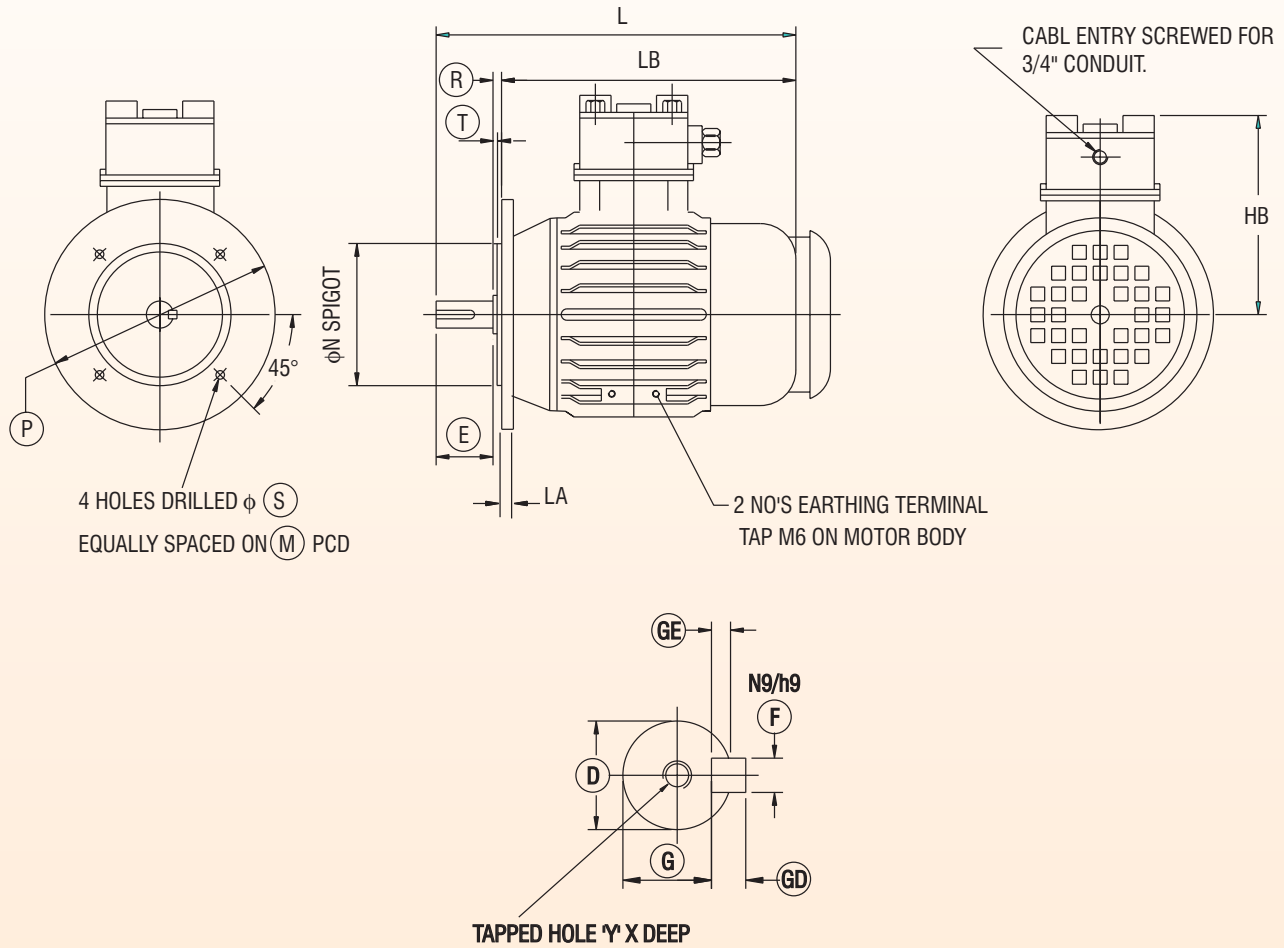

FRAME SIZE	FLANGE			FLANGE FIXING						SHAFT AND KEY						OVERALL (MAX)						
	REF	M	N	TOL	P	R	S	T	LA	D	TOL	E	ED	F	G	GA	GD	GE	AC	HB	L	LB
E80	F165B	165	130	+0.014 -0.011	200	0	12	3.5	10	19	+0.009 -0.004	40	27	6	15.5 15.4	21.5	6	3.5	165	190	325	285



FLP Motors

OUTLINE DIMENSION DRAWING FOR 3 PHASE SQUIRREL CAGE TEFC FLANGE MOUNTED FLAME PROOF INDUCTION MOTORS (4 POLE & UP FOR ALL FRAMES & 2 POLE & UP, UP TO ND200L FRAME.)

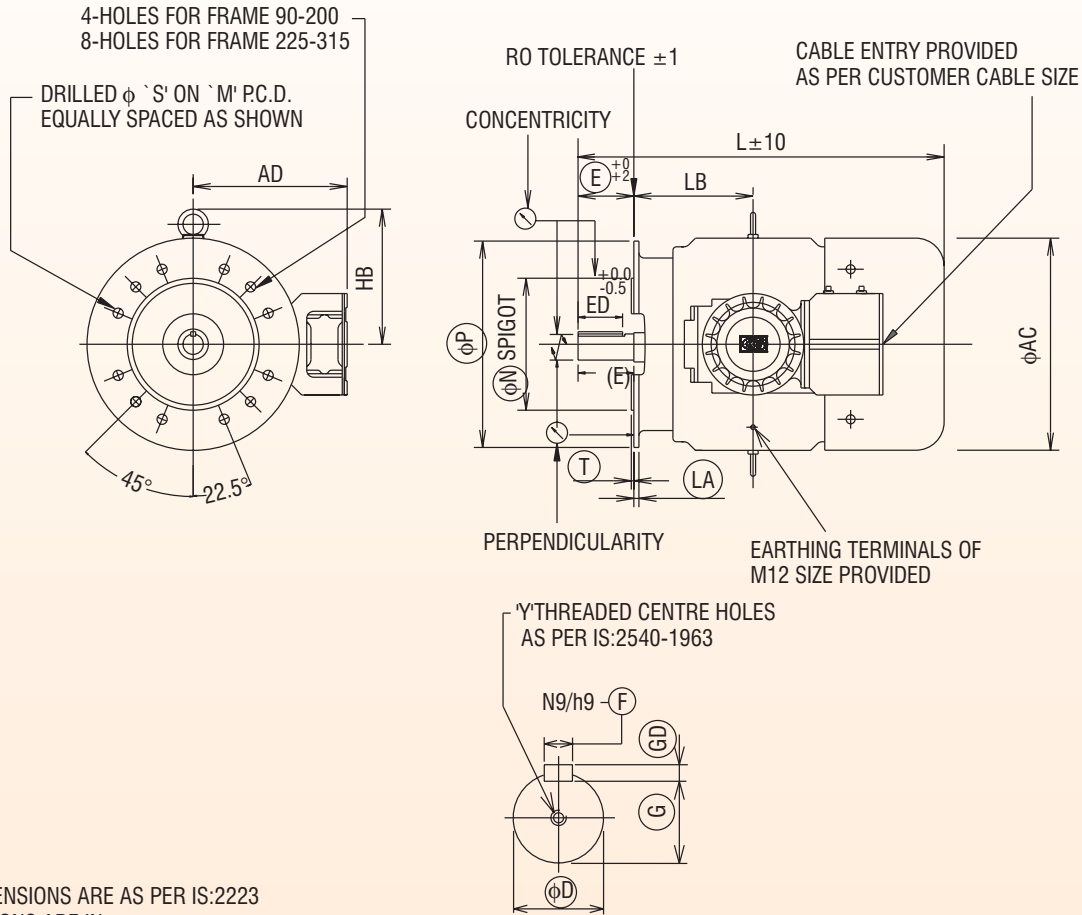

RINGED DIMENSIONS ARE AS PER IS:2223
ALL DIMENSIONS ARE IN mm

Frame	D	E	ED	F	GD	G	Y	AD	AC	L	M Tol	N Tol	P	S	T	LA	LB	HB
E90L	24.018 24.002	50	32	8.00 7.957	7.00 6.91	20.0 19.8	M10x22	240	210	385	165.5 164.5	130.5 129.5	200	12	3.5	10	---	150
E100L	28.018 28.002	60	40	8.00 7.958	7.00 6.92	24.0 23.8	M10x22	255	240	410	215.5 214.5	180.5 179.5	250	15	4	11	--	165
E112M	28.018 28.003	60	40	8.00 7.958	7.00 6.92	24.0 23.8	M10x22	270	270	430	215.5 214.5	180.5 179.5	250	15	4	11	--	175
E132M	38.018 38.002	80	56	10.00 9.957	8.00 7.92	33.0 32.8	M12x28	290	320	520	265.5 264.5	230.5 229.5	300	15	4	13	--	220
E160L	42.018 42.002	110	80	12.00 11.957	8.00 7.91	37.0 36.8	M16X32	345	320	655	300.5 299.5	250.016 249.987	350	19	5	18	235	220
E180L	48.018 48.002	110	80	14.00 13.957	9.00 8.91	42.5 42.3	M16X32	362	370	750	300.5 299.5	250.016 249.987	350	19	5	18	261	245
E200L	55.030 55.011	110	80	16.00 15.957	10.00 9.91	49.0 48.8	M20X40	400	435	790	350.5 349.5	300.016 299.984	400	19	5	18	286	280
E225M	60.030 60.011	140	110	18.00 17.957	11.00 10.91	53.0 52.8	M20X40	402	490	857	400.5 399.5	350.018 349.982	450	19	5	19	305	300
E225S	60.030 60.011	140	110	18.00 17.957	11.00 10.91	53.0 52.8	M20X40	402	490	832	400.5 399.5	350.018 349.982	450	19	5	19	292	300
E250M	65.030 65.011	140	110	18.00 17.957	11.00 10.91	58.0 57.8	M20X40	440	560	977	500.5 499.5	450.020 449.980	550	19	5	22	343	355
E280M	75.030 75.011	140	110	20.00 19.48	12.00 11.91	67.5 67.3	M20X40	476	620	1094	500.5 499.5	450.020 449.980	550	19	5	22	400	380
E315M	80.030 80.011	170	140	22.00 21.948	14.00 13.91	71.0 70.8	M20X40	516	705	1220	601.0 599.0	550.022 549.978	660	24	6	25	445	460



FLP Motors

OUTLINE DIMENSION DRAWING FOR 3 PHASE SQUIRREL CAGE TEFC FLANGE MOUNTED FLAME PROOF INDUCTION MOTORS (FOR 2 POLE)

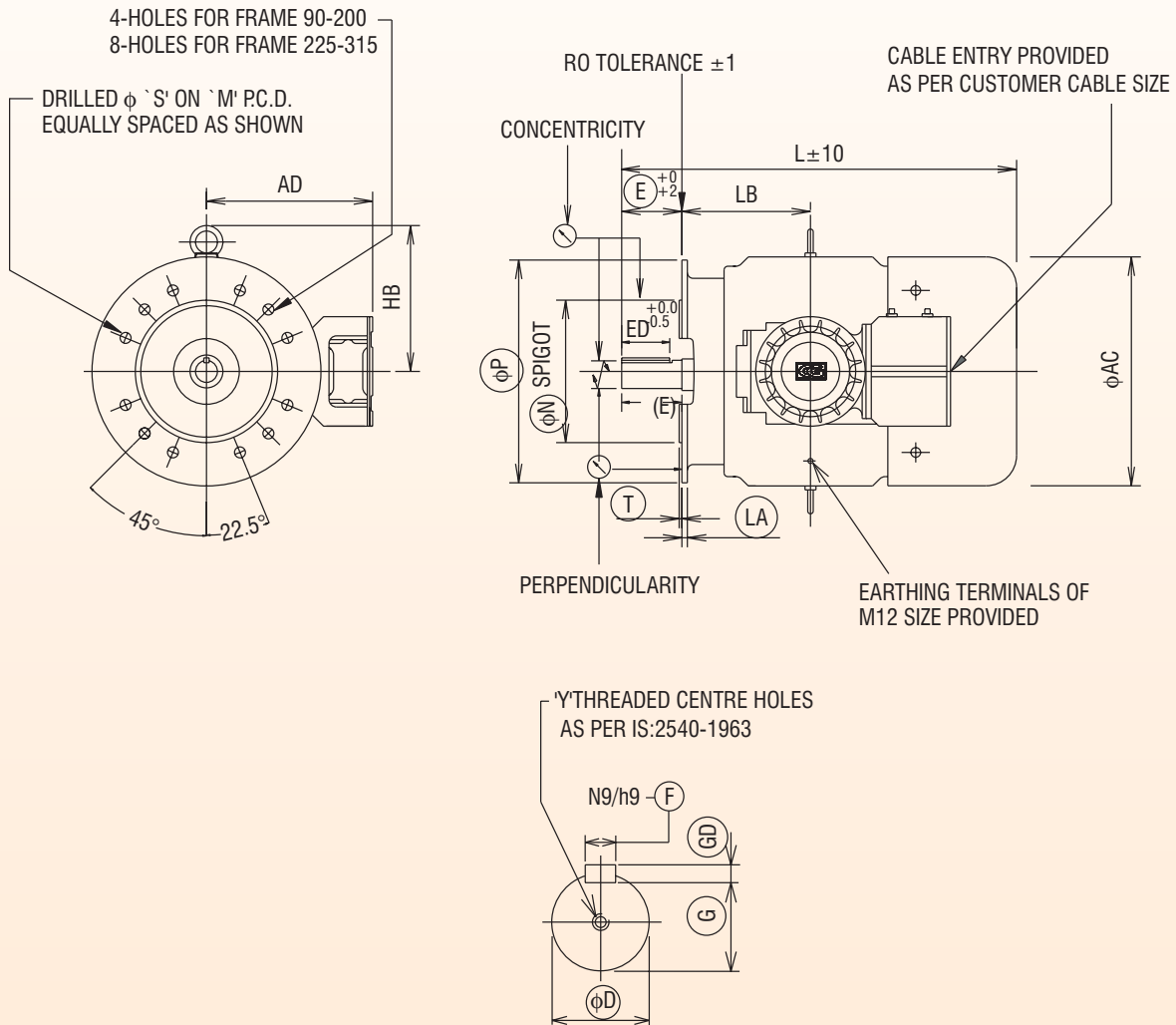

RINGED DIMENSIONS ARE AS PER IS:2223
ALL DIMENSIONS ARE IN mm

Frame	D	E	ED	F	GD	G	Y	AD	AC	L	M Tol	N Tol	P	S	T	LA	LB	HB
E225M	55.011 55.030	110	80	15.957 16.00	10.00 9.91	48.8 49.0	M20X40	402	490	827	399.5 400.5	349.982 350.018	450	19	5	19	305	300
E250M	60.030 60.011	140	110	18.00 17.957	11.00 10.91	53.0 52.8	M20X40	440	560	977	500.5 499.5	450.020 449.980	550	19	5	22	343	355
E280M	65.030 65.011	140	110	18.00 17.957	11.00 10.91	58.0 57.8	M20X40	476	620	1094	500.5 499.5	450.020 449.980	550	19	5	22	400	380
E315M	65.030 65.011	140	110	18.00 17.957	11.00 10.91	58.0 57.8	M20X40	516	705	1190	601.0 599.0	550.022 549.978	660	24	6	25	445	460



FLP Motors

OUTLINE DIMENSION DRAWING FOR 3 PHASE SQUIRREL CAGE TEFC FLANGE MOUNTED FLAME PROOF INDUCTION MOTOR.(FRAME : E315L)

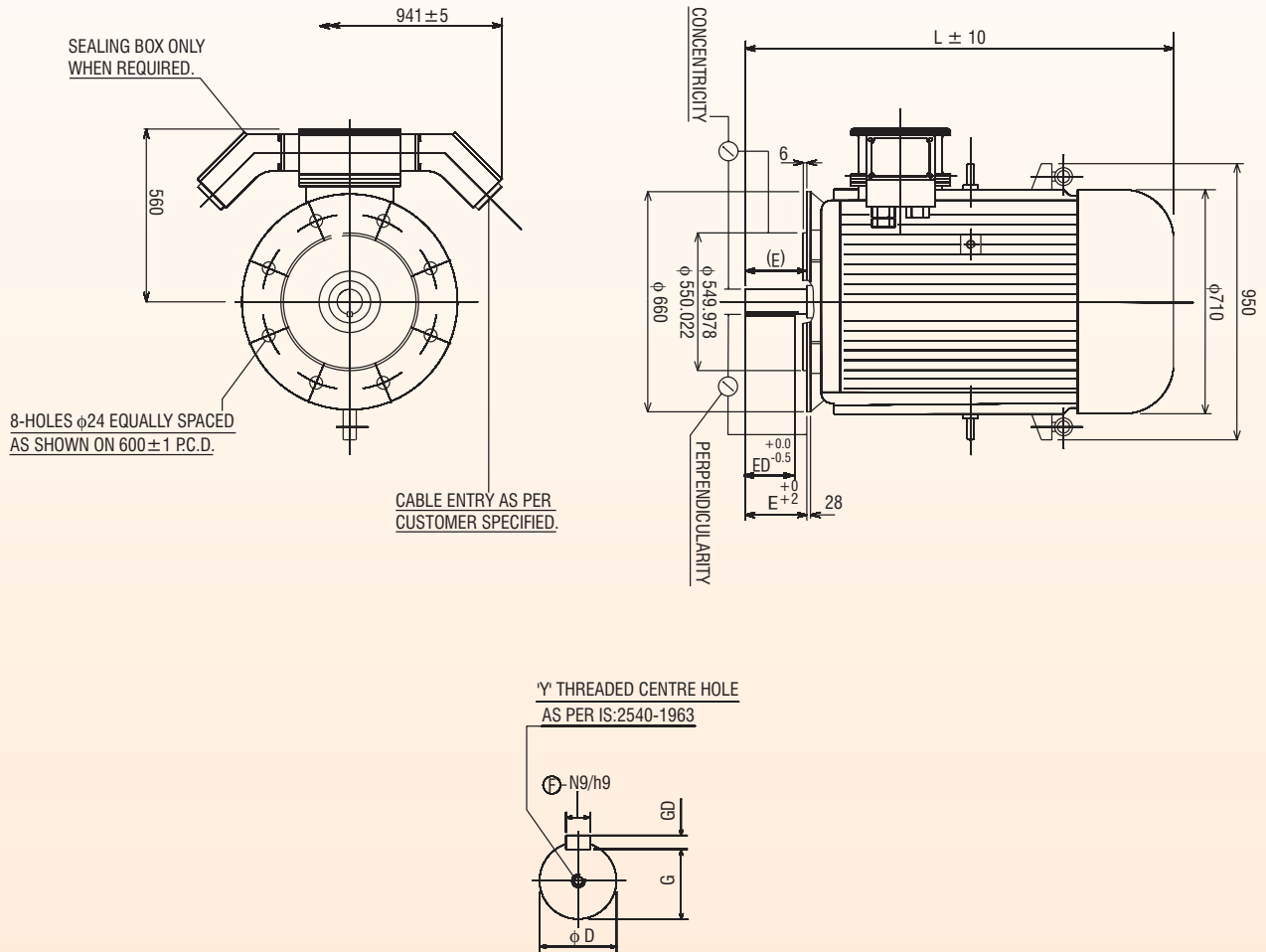

POLE	SHAFT AND KEY							
	D TOL.	E	ED	F TOL.	GD TOL.	G	Y	L
4P & UP	90.035/90.013	170	140	25.0/24.948	14.0/13.91	81.0/80.8	M24x50	1492
2	70.030/70.011	140	110	20.0/19.948	12.0/11.91	62.5/62.3	M20x40	1462

AC Generators



**5 kVA to 625 kVA
From 132 to 355 Frame**

CE
For Brushless



AC Generators

Crompton Greaves AC Generators are state-of-the-art, self-excited, self-regulated and dependable source of power.

A modern integrated manufacturing facility for rotating machines, ISO 9001 certified by BVQI UK, with structured TQM and 6 SIGMA implementation and SAP/R3 enabled, also houses dedicated plant for AC Generators deploying superior techniques and processes in each specialized field of design, material specifications and procurement, CNC machining, assembly, testing & packing.... with stringent quality standards predominating throughout.

These generators incorporate advanced European Technology and are designed for optimum performance using high-end software solutions. With well-qualified engineers and technocrats, backed by a strong R & D Team, Crompton Greaves have fully harnessed long experience in design and software to offer a range of innovative, reliable and efficient AC Generators.

SPECIFICATIONS AND OPTIONAL FEATURES :

Specifications	Standard	Optional
Rated Voltage	415 V - 3 Ph & 230 V - 1 PH	380, 400 - 3 Ph & 220 V - 1 Ph (Only for 160 & 200 Frame ratings i.e. 15-100 kVA) (For other ratings in consultation with Works)
Terminals	6 Leads	12 lead reconnectable only for 160 & 200 Frame Brushless alternators i.e. 15 to 100 kVA.
Voltage Regulation	± 1% (Brushless) ± 5% (Slipping)	Nil
Speed	1500 RPM	1800 RPM in consultation with Works
Direction of rotation	CW from drive end	Nil
Phase Sequence	UVW	Nil
Overspeed	1.2 times normal speed for 2 min.	Nil
Insulation Class	Class 'H' with Class 'H' Temperature rise	For Temperature rise restrictions to other class of insulation, refer to works
Type of Mounting	B3 & B2	For availability of different SAE Housings & Coupling Disc refer Table below.
Degree of Protection	IP23	Nil
Duty Rating	Continuous (S1)	Nil
Short circuit withstand capability	3 Times FLC for 3 Sec	Nil
10% Overload	1 Hour in 6 Hours	Nil
Parallel Operation Provision	> 160 kVA	< 160kVA
Harmonic Distortion Factor at NL L-L	< 3%	Nil
Max Unbalanced Load	Max 25%	Nil
TVD (AT FL 0.8 PF)	15-20%	Please refer for better TVD
TVR (AT FL 0.8 PF)	18-20%	Please refer for better TVR



AC Generators

SPECIAL FEATURES

- Ease of maintenance with integrated components and outboard Exciter/Rotating Rectifier.
- A reliable long life with superior class 'H' insulation.
- Higher motor starting capability.
- Compact, light and sturdy die cast aluminum stator for frames upto 250, offer superior finish.
- Specially designed compact slipring and brush assembly.
- High thyristor load withstand capability for Cell-Phone and Telecom applications.
- Short circuit withstand capability.
- Wide range of coupling discs / adaptor for single bearing construction suitable for wide range of Engine makers.

APPLICATIONS

- Industries
- Telecom, Cell-Phone Towers
- Defence
- Agriculture
- Marine.
- Hotels, Hospitals, Commercial & Residential Complexes, Petrol pumps
- Construction sites, Stone Crushers & hot Mixing plants.
- Trailer mounted mobile sets for rental markets

RANGE :

Brushless AC Generators :

- 5 kVA to 625 kVA, in 3 phase, 415 V, 50 Hz, 0.8 pf (lag) Single or double bearing.
- 5 kVA to 30 kVA in single phase, 230 V, 50 Hz, 0.8 pf (lag) Single & double bearing

Slip-Ring AC Generators :

- 5 kVA to 82.5 kVA, in 3 phase, 415 V, 50 Hz, 0.8 pf (lag) Single or double bearing.
- 5 kVA to 15 kVA in single phase, 230 V, 50 Hz, 0.8 pf (lag) Single & double bearing
- 2 Pole Alternators (both Slipring and Brushless) are available on request.





AC Generators

OPERATING IN DIFFERENT ENVIRONMENTS

- For use of the AC Generator at altitudes higher than 1000 m. above the sea level, it is necessary to derate by a factor of 4% for every 500 m above 1000 m
- If the ambient temperature exceeds 40 deg. C, the derating factor to be incorporated is 4% for every 5 deg. C of increase.

STANDARDS COMPLIANCE

- IEC : 34
- BS : 5000 (Part 99)
- EN : 50081
- IS : 4722 & 13364 (Part I & II) with CE mark for brushless designs.

MECHANICAL FEATURES

- Aluminium frame die - cast stator upto 250 and steel stator for higher frames.
- Sturdy cast iron endshields fixed on to the stator frame by high tensile screws.
- High quality steel shafts are amply designed to take care of overload and short circuit stressed conditions.
- Sturdy, dynamically balanced rotors are designed for withstanding the runaway engine speed and are with continuous damper cage for high performance under arduous conditions of parallel operations.
- Aluminum fans for effective cooling extends the winding life.
- Screens or louvered covers on all

STANDARD SAE HOUSING & COUPLING DISC COMBINATION :

Frame	SAE5	SAE4	SAE3	SAE2	SAE1	SAE1/2	SAE0
132	●	●	●				
160	●	●	●	●			
200		●	●	●	●		
250			●	●	●		
280			●	●	●	●	
315			●	●	●	●	
355					●	●	●
C.Disc	6.5", 7.5"	6.5", 7.5"	10", 11.5"	10", 11.5"	11.5", 14"	11.5", 14"	14", 18"

openings for safety.

- Easy mount SAE adaptors are offered with single bearing AC Generators to simplify coupling with popular engines.

AUTOMATIC VOLTAGE REGULATOR (AVR)

Model	Frame
SR 7/3	132 & 160 Frame
SR 7/6	200 & 250 Frame
UVR 6	280 & Above
SR 7/5	For Slipring (on request)

- Under Speed Protection with LED indicator.
- Over Excitation Protection with LED indicator
- 2 Phase sensing with Senseless LED Indicator
- Designed for Thyristor load without additional filter circuits.
- Moulded construction for protection against shocks, vibrations and adverse atmospheric conditions.

UNDER SPEED PROTECTION (with AVR)

Protects both the AC Generator and V/f sensitive loads. The AVR has provision for setting the frequency below which voltage dropping occurs linear to speed. This feature also enables the prime mover to recover the speed faster during motor starting

WINDING AND INSULATION SYSTEM

The armature coils of the stator main winding are made from dual coated, class 'H' copper wires, Single/Double Layer concentric fractional pitched

winding offers simplicity, reduced overhangs, neat look while reducing voltage distortion and superior capability to cope with non-linear loads. The auxiliary winding in stator provides power to the AVR, improving the motor starting capability of the AC Generator.

The insulation system is class 'H'. All wound components are impregnated in an unsaturated polyester resin of 200 class temperature. The impregnation provides much needed rigidity and protection against the harsh environment, typical for the AC Generators applications

RADIO INTERFERENCE

The AC Generators are having negligible Radio Frequency Interference and meets in general the limits permitted by VDE 0875 (N)

WAVE FORMS

A.C. Generators are designed to give an excellent output wave-form. The total harmonic content of line-to-line voltage wave-form on no load is less than 5% as per the limits specified by IEC/IS Standards.

OVERLOADS

A.C. Generators are capable of delivering an overload of 10% for one hour after every six hours of running.

MOTOR STARTING DUTY

Each kVA of AC Generator is capable of starting 1 HP of Induction Motor with use of auxiliary winding except for Submersible Pump & Lift Duty applications. (Upto 200 frame slipring type only)

VIBRATION AND NOISE

CNC machining with close tolerances and repeat Accuracy for uniform air - gap and rotor dynamic balancing for low vibrations ensure efficient, smooth and silent performance.

TERMINATION

- Integral Terminal Box is provided for higher reliability.
- Top Terminal Box with side cable entry ensures wiring flexibility.
- Spacious terminal box accommodates all types, including aluminum cables



AC Generators

PERFORMANCE

Slipring AC Generators - Voltage Reg. \pm 5%			
kVA	Frame (G2S/ G1S)	% Efficiency	
		FL	3/4 FL
3 PH, 415V, 50 Hz, 4 Pole, 1500 RPM, 0.8 pf			
6.5	132MR	81	82
7.5	132MA	82.5	83.5
10.0	132MC	83.8	84.5
12.5	132MD	84.0	85.0
15.0	160S1A	85.0	86.0
20.0	160SC	85.0	85.5
25.0	160MA	86.0	86.6
30.0	160MB	87.0	87.5
32.5	160MB	87.5	88.0
35.0	160MB	88.0	88.4
40.0	200SE	88.0	89.0
45.0	200SB	89.0	89.5
50.0	200SB	88.1	89.2
63.0	200SD	89.2	90.1
75.0	200MD	90.0	91.0
82.5	200MD	90.3	91.2

Slipring AC Generators - Voltage Reg. \pm 5%			
1 Phase, 230V, 50 Hz, 4 Pole, 1500RPM, 0.8pf			
5	132MA	76	78
6	132MC	77.2	78.0
7.5	132MD	78.0	78.4
10	160SB	78.5	79.0
12.5	160SC	79.5	80.5
15	160MA	80.0	81.0

Brushless AC Generators - Voltage Reg. \pm 1%			
1 Phase, 230V, 50 Hz, 4 Pole, 1500 RPM, 0.8pf			
5	132MA	74.5	75.2
7.5	132MD	78.2	78.8
10	160S1B	78.5	79.0
12.5	160SB	79.5	80.5
15	160SC	80.0	81.0
20	160MR	81.0	81.5
25	200SA	82.0	82.5
30	200SB	82.5	83.2

Note: 1. The efficiency figures are subject to the tolerance as per IS: 13364 (Part II & I).

2. Continuous development of products entitles us to change specification details without notice.

Brushless AC Generators - Voltage Reg. \pm 1%			
kVA	Frame (G2R/ G1R)	% Efficiency	
		FL	3/4 FL
3 PH, 415V, 50 Hz, 4 Pole, 1500 RPM, 0.8 pf			
5.0	132MR	80.4	81.3
7.5	132MA	82.5	83.0
10.0	132MC	83.0	83.5
12.5	160S1A	83.0	84.0
15.0	160S1A	83.5	84.5
20.0	160SB	85.5	86.1
25.0	160SC	86.9	87.5
30.0	160MA	88.5	89.0
35.0	200SE	87.0	87.5
40.0	200SE	88.1	88.8
45.0	200SA	89.0	89.7
50.0	200SB	88.5	89.2
63.0	200SC	90.6	90.9
75.0	200SD	90.9	92.0
82.5	200MD	90.5	91.2
100	200MDX	90.2	91.0
110	AL 250SC	92.0	92.6
125	AL 250SC	92.2	92.8
140	AL 250MA	92.3	92.8
160	AL 250MB	92.5	93.0
180	AL 250LB	92.9	93.6
200	AL 250 LD	93.1	93.7
225	315SE	93.0	93.7
250	315SE	93.2	93.9
275	315SA	93.4	93.2
285	315SA	93.6	93.7
300	315SB	94.1	93.8
320	315SB	94.0	94.1
350	315MB	94.0	93.8
380	315MB	94.2	94.1
400	315MB	94.1	94.2
437.5	355SB	94.1	94.7
475	355SC	94.2	94.9
500	355SC	94.4	95.0
550	355ME	94.6	95.1
625	355MA	94.9	95.4



AC Generators

OUT-LINE DIMENSION DRAWING FOR SINGLE BEARING AC GENERATOR

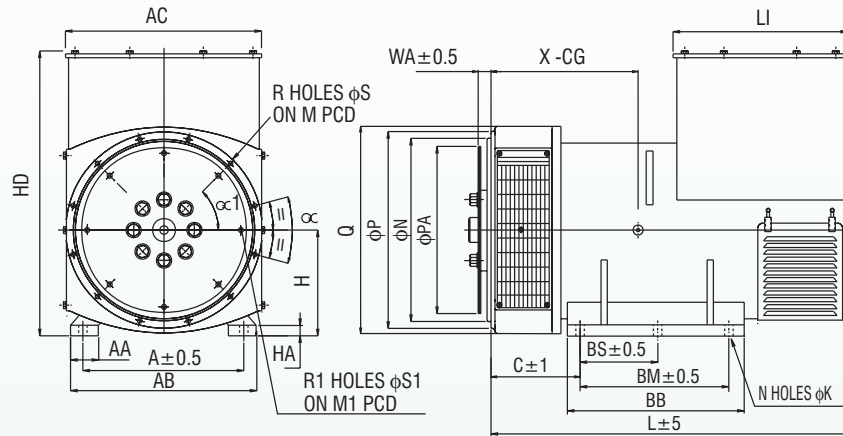

DIMENSIONS in Millimeters

FRAME	M/C WT.(Kg)		A	AA	AB	AC	BB	BS	BM	C	H	HA	HD	N	K	L		L1	X								
	G1R	G1S														G1R	G1S										
132 MR	70	70	206	56	256	272	122	-	56	380	132.0	12	365	4	12	550	520	296	194								
132 MA	77	77																	209								
132 MC	86	86																	232								
132 MD	94	94																	249								
132 LC	105	105																	254								
160 S1A	112	--	254/279	60	340	297	335	40	70	175	160.00	16	403	6	15	492	262	205									
160 S1B	122	--																220									
160 SA	124	--	270	70	340	350	196	-	95	293	160.00	16	418	4	15	578	300	205									
160 SB	134	--																220									
160 SC	144	135																230									
160 MA	169	160					306	110	205	293				306	110			205	293	160.00	16	418	6	15	688	300	275
160 MR	177	--																									285
160 MB	189	180																									295
200 SE	190	179																									340
200 SA	220	207	280																								
200 SB	239	226	225	-	120	363	225	-	120	363	200.00	20	510	4	19	816	350	300									
200 SC	250	--																315									
200 SD	267	254																330									
200 MD	342	329	325	110	230	353	325	110	230	353	200.00	20	510	6	19	816	350	370									
200 MDX	348	--																400									
AL 250SB	350	--	420	90	510	530	305	116	216	216	250.0	20	625	6	19	900	376	315									
AL 250SC	400	--																330									
AL 250MA	440	--																370									
AL 250MB	480	--																400									
AL 250LB	506	--																415									
AL 250LD	550	--																435									
315 SE	719	--	508	75	570	640	525	228.5	457	242	315.00	20	850	6	28	1080	415	380									
315 SA	853	--																460									
315 SB	953	--																480									
315 MB	1029	--																520									
355 SB	1137	--	610	75	670	685	570	250	500	297	355.0	20	980	6	28	1240	560	550									
355 SC	1287	--																570									
355 ME	1487	--																580									
355 MA	1607	--																620									

SAE No	FLANGE										COUPLING DISC SAE
	φ N	φ P	M	Q				R	φ S	∠	
				250	280	315	355				
5	314.3	356	333.4	-	-	-	-	8	11	45°	7 1/2"
4	362	405	381.0	-	-	-	-	12	11	30°	7 1/2"-10"
3	409.6	450	428.6	500	580	-	-	12	11	30°	10"-11 1/2"
2	447.7	490	466.7	500	580	620	-	12	11	30°	10"-11 1/2"
1	511.18	553	530.4	554	580	620	708	12	12.5	30°	11 1/2"-14"
1/2	584.18	648	619.0	-	670	680	715	12	14	30°	14"-18"
0	647.7	712	679.5	-	-	-	715	12*	14	22.5°	14"-18"

SAE No	COUPLING DISC					
	φ PA	M1	R1	φ S1	∠ C1	WA
6 1/2"	215.9	200.0	6	9	60°	30.2
7 1/2"	241.3	222.3	8	9	45°	30.2
10"	314.32	295.3	8	11	45°	53.8
11 1/2"	352.42	333.4	8	11	45°	39.6
14"	466.72	438.2	8	13.5	45°	25.4
18"	571.4	543.0	6	16.7	60°	15.87

* 12 Holes of φ14 (16 Holes spacing)



AC Generators

OUT-LINE DIMENSION DRAWING FOR DOUBLE BEARING AC GENERATOR

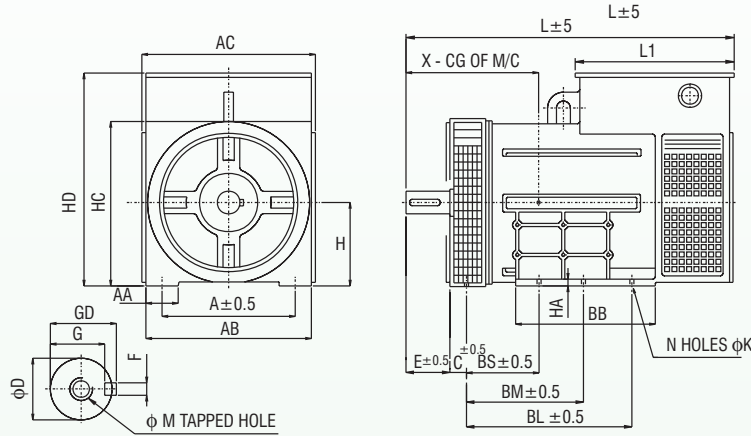

DIMENSIONS in Millimeters

FRAME	M/C WT.(Kg)		A	AA	AB	AC	BB	BS	BM	BL	C	D	E	F	G	GD	H	HA	HC	HD	N	K	L		L1	M	X		
	G2R	G2S																					G2R	G2S					
132 MR	-	70	206	56	256	272	122	316	372	--	45	38.018	38.002	80	10	33.0	41.0	132.0	131.5	12	260	365	6	12	611	581	296	M12	284
132 MA	-	77																											339
132 MC	-	86																											344
132 MD	-	94																											335
132 LC	-	105																											344
160 SA	121	--	270	70	340	350	196	197	292	-	66	48.018	48.002	110	14	42.5	51.5	160.0	159.5	16	323	418	6	15	658	300	M16	335	
160 SB	131	--																										350	
160 SC	141	132																										360	
160 MA	166	157																										400	
160 MR	174	--																										410	
160 MB	186	177																										420	
200 SE	190	179	340	75	410	424	225	280	400	-	57	60.030	60.011	140	18	53.0	64.0	200.0	199.5	20	403	510	6	19	705	350	M20	335	
200 SA	217	204																										420	
200 SB	236	223																										420	
200 SC	250	--																										435	
200 SD	264	251																										450	
200 MD	335	322																										520	
200 MDX	342	--																										525	
AL 250SB	350	--	420	90	510	530	305	225	341	441	66	70.030	70.011	140	20	62.5	74.5	250.0	249.5	20	510	625	8	20	885	376	M20	425	
AL 250SC	400	--																										450	
AL 250MA	440	--																										465	
AL 250MB	480	--																										520	
AL 250LB	506	--																										535	
AL 250LD	550	--																										555	
315 SE	719	--	508	75	570	640	525	228.5	457	-	216	80.030	80.011	170	22	71.0	85.0	315.00	314.50	27	620	850	6	28	1150	415	M20	380	
315 SA	853	--																										460	
315 SB	953	--																										480	
315 MB	1029	--																										520	
355 SB	1137	--	610	75	670	685	570	250	500	-	254	95.035	95.013	170	25	86.0	100	355.00	354.50	27	706	940	6	28	1360	560	M24	660	
355 SC	1287	--																										702	
355 ME	1518	--																										710	
355 MA	1587	--																										750	



AC Generators

High Speed Brushless Alternators

Manufacturing Range :

5kVA to 15kVA, 1 Phase, Brushless with AVR
5kVA to 40kVA, 3 Phase, Brushless with AVR

Rating Chart :

2 Pole, 3000 RPM Brushless Alternator
Voltage Regulation $\pm 2.5\%$, IP21/23, B3 Mounting, 0.8 PF, 40 Deg. C Amb.

Brushless Alternator : 1 Phase, 230V

kVA	FRAME SIZE	EFFICIENCY	
		75%	100%
5.0	G2R 132MR/2	73.3	72.3
6.0	G2R 132MA/2	76.2	75.1
7.5	G2R 132MC/2	78.1	77.2
10.0	G2R 160S1A/2	79.0	78.3
12.5	G2R 160SB/2	79.1	78.5
15.0	G2R 160SC/2	79.8	79.3

Brushless Alternator : 3 Phase, 415V

kVA	FRAME SIZE	EFFICIENCY	
		75%	100%
5.0	G2R 132MR/2	76.0	75.6
7.5	G2R 132MA/2	79.2	78.1
10.0	G2R 132MC/2	80.2	81.9
12.5	G2R 132MD/2	82.2	81.8
15.0	G2R 160S1A/2	84.5	84.0
20.0	G2R 160SB/2	85.8	85.2
25.0	G2R 160SC/2	87.2	86.5
30.0	G2R 160MA/2	87.4	86.8
35.0	G2R 160MB/2	86.5	87.2
40.0	G2R 160MB/2	87.5	87.0

REPRESENTATIVE OUT-LINE DIMENSION DRAWING FOR DOUBLE BEARING AC GENERATOR (2 POLE, BRUSHLESS)

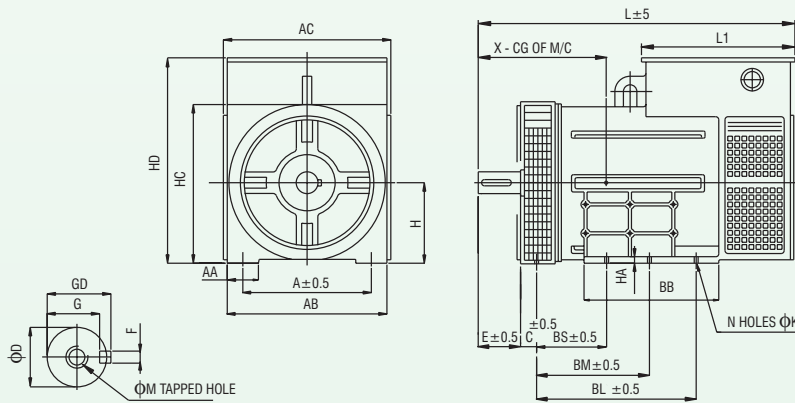

DIMENSIONS in Millimeters

FRAME	WT. (KG)	A	AA	AB	AC	BB	BS	BM	BL	C	ØD	E	F	G	GD	H	HA	HC	HD	N	ØK	L	L1	ØM	X
132MR	70	206	56	256	272	122	316	372	-	45	Ø38.018 Ø38.002	80	10	33.0 32.8	41.0 40.8	132.0 131.5	12	260	365	6	12	611	296	M12	284
132MA	77																								299
132MC	86																								322
132MD	94																								339
132LC	105																								344
160SB	131	270	70	340	350	196	197	292	-	66	Ø48.018 Ø48.002	110	14	42.5 42.3	51.5 51.3	160.0 159.5	16	323	418	6	15	768	300	M16	350
160SC	141																								360
160MA	166																								400
160MB	186																								420
160S1A	112																								254/279

Note : Options in Single Bearing Construction : Frame 132 : SAE5 - 7.5", SAE4 - 7.5", SAE3 - 10", 11.5", Frame 160 : SAE5 - 7.5", SAE4 - 7.5", SAE3 - 10", 11.5"
Continuous development of products entitles us to change specification details without notice.

DC Motors

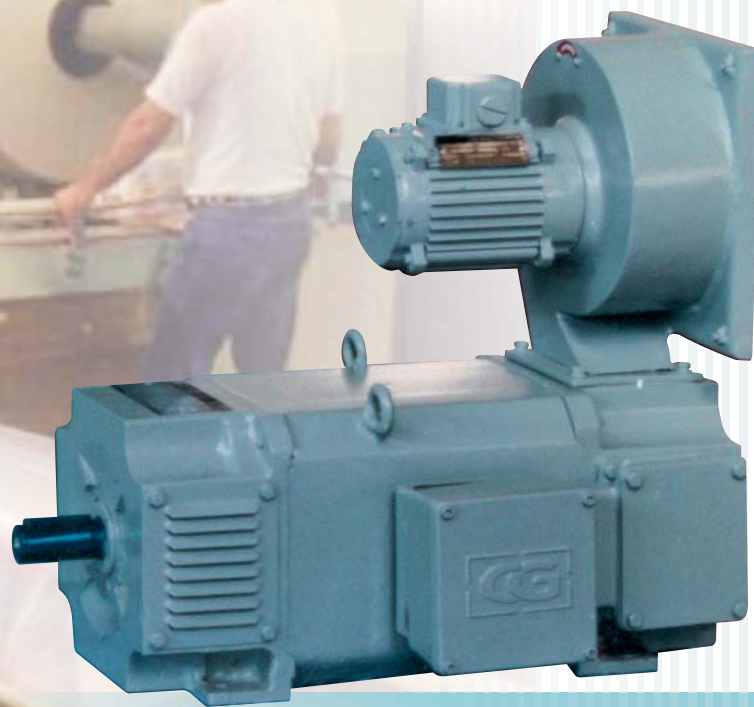

2.5 kW to 450 kW
From 100 to 280 Frame



DC Motors

INTRODUCTION

Crompton Greaves Ltd, a name synonymous with rotating machines have DC Motors Technology inherited from SIEMENS, Germany, the pioneer and world leader in DC Motors. Today, Crompton Greaves offers an entire range of world class DC Motors.

The motors are manufactured at Crompton Greaves Ltd. Ahmednagar factory, an ISO accredited set up having state - of - the - art manufacturing facilities. The high quality standards maintained in manufacturing and testing give superior electrical and mechanical features - making the motors most suitable for operating in tropical environments.



The Ahmednagar factory - manufacturing DC Motors

SPECIAL FEATURES

- Fully laminated yoke construction offering excellent commutation - suitable for 6 pulse thyristor power supply
- Skewed Rotor construction - ensuring low noise
- Vacuum pressure impregnation for armature winding - ensuring high insulation strength
- High dynamic response

APPLICATIONS

- Plastic Extruders
- Printing Machines
- Steel Rolling Mills and Wire Rod Mills
- Sugar Industry
- Textile Mills
- Apron Feeders
- Machine Tools
- Rubber Industry
- Cement Mills
- Cable Industry
- Paper Mills
- Material Handling



Laminated Yoke DC Motor manufactured at Ahmednagar

- Compact, low weight and highly energy efficient
- Larger size of bearings - for longer life and trouble free operations
- Constant / uniform pressure brush holders
- Easy fitting and retro-fitting of filters

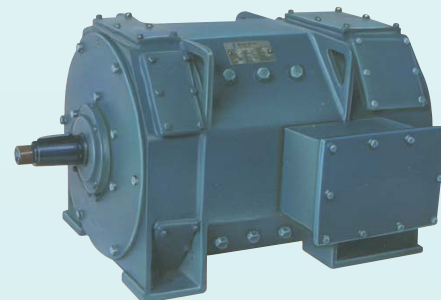

Aux Mill Duty DC Motors as per IPSS/AISE Standards are also manufactured



DC Motors

SPECIFICATIONS

Laminated Yoke Construction Range :
Output : 1.2 kW to 450 kW
Frames : ASBG 100 to ASBG 280

DESIGN PARAMETERS	STANDARD	OPTIONAL
ARMATURE VOLTAGE	440 V	MAX. 470 V UPTO FRAME 132, MAX. 600 V ABOVE FRAME 160
FIELD VOLTAGE	220 V	MAX. UPTO 500 V
EXCITATION TYPE	SHUNT	SERIES
INSULATION	CLASS 'F' UPTO 132 CLASS 'H' ABOVE 160	CLASS 'H'
TYPE OF MOUNTING	B3	B35, V1, V3
DEGREE OF PROTECTION	IP 23	IP 54 WITH IC 37 (HEAT EXCHANGER)
ARRANGEMENT OF T. BOX	RHS FROM DE SIDE	ANY OTHER ARRANGEMENT
TACHO MTG. PROVISION	DTG 4000	ANY OTHER
TYPE OF MOUNTING OF BLOWER	TOP ON NDE SIDE	ANY OTHER MOUNTING
AIR FLOW DIRECTION	FROM NDE TO DE	FROM DE TO NDE
AIR FILTER	NIL	DRY TYPE FILTER (RECOMMENDED FOR DUSTY ENVIRONMENT)
AIR FLOW SWITCH	NIL	VENTCAPTOR AIR FLOW MONITOR
BEARINGS	BALL BEARINGS	ROLLER BEARING ON DE SIDE FOR HIGH CANTILEVER FORCES
SHAFT END	WITH KEYWAY, BALANCING WITH FULL KEY	DOUBLE SHAFT EXTENSION WITHOUT TACHO MOUNTING ARRANGEMENT
SPACE HEATER	NIL	230 V, 1 PH
THERMISTER	NIL	FOR TRIP. FOR ALARM AND TRIP
PAINT FINISH	631 OF IS:5	PRIMER ONLY / ANY OTHER SHADE

BRUSH LIFETIME

FRAME	TIME IN Hrs.
Upto 160	15000
180	14000
200	12500
225	11000
250	11000
280	11000

BRUSH MATERIAL, COMMUTATION :
Practically sparkless commutation with converter feeding, even under overload conditions is achieved. As a result, the brushes have an extremely long life.

NOISE LEVEL

FRAME	MEASURING SURFACE SOUND PRESSURE LEVEL IN dB(A)*
100	<70 dB
112	<70 dB
132	<70 dB
160	<75 dB
180	<75 dB
200	<75 dB
225	<85 dB
250	<85 dB
280	<85 dB

The noise levels of the motors have been calculated in accordance with DIN EN 21 680 and are well below the values permitted by EN 60034 - 9. They have been achieved both by means of design measures and by optimising the magnetic circuit and the separately driven fans.

*** At No Load, with blower ON, with thyristor supply**

FORCED COOLING DETAILS

FRAME	COOLING AIR FLOW IN m ³ /sec	REQUIRED PRESSURE HEAD IN miliBar
ASBG 100	0.06	5
ASBG 112	0.07	5
ASBG 132	0.09	5
ASBG 160	0.20	13
ASBG 180	0.30	13
ASBG 200	0.35	13
ASBG 225	0.50	16
ASBG 250	0.60	16
ASBG 280	0.75	16

The blowers of DC Motors have three phase motors with wide range of winding and supply voltages. The blower motors are selected strictly in accordance with the air quantity required and ensures cool running of motors under the specified operating loads / overloads. The terminal box of blower motors are easily assessible.

FILTER MOUNTING :

A dry type air filter can be mounted or retro-fitted on all the DC Motors without derating.



DC Motors

TECHNICAL DATA

RATED OUTPUT IN KW AT 1500 RPM	FRAME	RATED TORQUE IN Nm	RATED ARM. CURRENT	EFFICIENCY	FIELD POWER IN watt	MAX. FIELD WEAKENING SPEED	MAX. SAFE MECH. SPEED	MOMENT OF INERTIA IN kg-m ²	WEIGHT IN kg
2.5	ASBG 100S	16	7.8	68	270	3350	5000	0.016	50
3.7	ASBG 100M	24	11.3	70	330	3250	5000	0.020	61
5.5	ASBG 100L	35	16.0	74	400	3100	5000	0.025	76
6.4	ASBG 112S	41	18.3	76	330	3550	4500	0.032	93
7.5	ASBG 112M	48	21.5	78	400	3750	4500	0.042	115
11	ASBG 132S	70	30.7	80	470	2400	4500	0.090	125
15	ASBG 132M	95	41.5	81	540	2400	4500	0.110	145
20	ASBG 132L	127	52.7	83	620	2200	4500	0.140	170
22.5	ASBG 132L	143	59.0	83	620	2200	4500	0.140	170
30	ASBG 160A	191	79	83	1810	3000	4000	0.290	290
40	ASBG 160S	255	105	83	1810	2350	4000	0.320	320
56	ASBG 160M	356	147	84	2080	1950	4000	0.380	365
60	ASBG 160L	382	157	85	2300	3000	4000	0.460	428
70	ASBG 180S	446	180	85	2500	3400	3500	0.6	460
80	ASBG 180M	509	203	87	2700	3300	3500	0.7	520
100	ASBG 180M	637	253	87	2700	3300	3500	0.7	520
115	ASBG 200S	732	291	88	2800	2800	3000	1.2	610
125	ASBG 200M	796	312	89	2900	3500	3000	1.3	690
135	ASBG 200M	859	337	89	2900	3300	3000	1.3	690
150	ASBG 200M	955	374	89	2900	3100	3000	1.3	690
158	ASBG 200M	1006	394	89	2900	3100	3000	1.3	690
160	ASBG 225S	1018	400	89	2900	2460	3000	2.2	880
180	ASBG 225M	1146	441	91	3500	2650	3000	2.5	990
210	ASBG 225M	1337	515	91	3500	2320	3000	2.5	990
225	ASBG 225M	1432	552	91	3500	2320	3000	2.5	990
235	ASBG 250S	1496	573	92	4000	2250	2500	3.6	1160
270	ASBG 250S	1719	658	92	4000	2025	2500	3.6	1160
280	ASBG 250S	1782	682	92	4000	1980	2500	3.6	1160
295	ASBG 250S	1878	719	92	4000	1980	2500	3.6	1160
325	ASBG 250M	2069	791	92	4700	1990	2500	4.2	1320
400	ASBG 280S	2546	965	93	4800	1710	2500	6.4	1560
450	ASBG 280M	2864	1079	93	5400	1450	2500	7.5	1780



DC Motors

DIMENSIONS

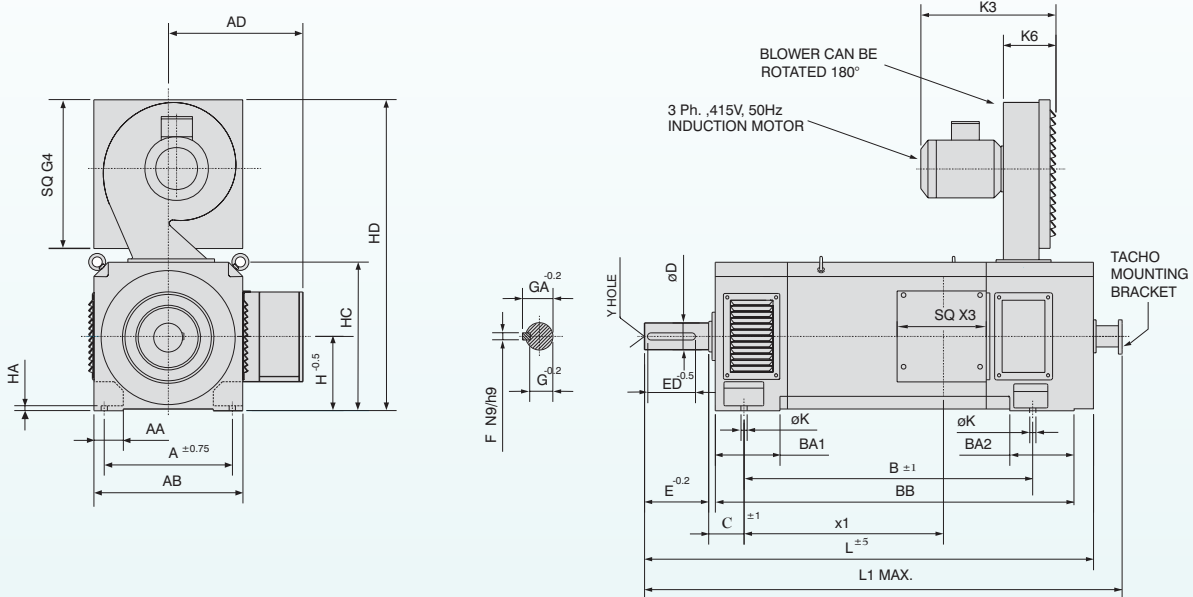

FRAME	SHAFT EXTENSION DETAILS								FOOT HOLE DIMENSIONS								OVERALL DIMENSIONS						BLOWER DIMENSIONS				
	H	D	F	G	GA	E	ED	Y	A	AA	AB	B	BA1	BA2	BB	C	HA	K	AD	HC	HD	X1	L	L1	K3	K6	G4
ASBG 100S	100	28	8	24	31	60	50	M10X24	160	40	198	257	60	60	290	63	9	12	190	200	445	120	460	535	235	100	220
ASBG 100M												305			340												
ASBG 100L												369			405												
ASBG 112S	112	38	10	33	41	80	70	M12X28	190	40	220	340	100	60	420	70	10	12	220	222	470	230	585	655	235	100	220
ASBG 112M												400			480							275	645	715			
ASBG 132S	132	42	12	37	45	110	90	M16X32	216	45	258	320	125	75	425	89	11	12	245	260	545	175	640	710	240	100	255
ASBG 132M												370			475							225	690	760			
ASBG 132L												430			535							285	750	820			
ASBG 160A	160	60	18	53	64	140	125	M20X42	254	55	316	530	140	125	630	70	12	14	305	318	680	245	785	852	355	120	310
ASBG 160S												590			690							305	845	915			
ASBG 160M												660			760							375	915	985			
ASBG 160L												750			850							465	1005	1075			
ASBG 180S	180	65	18	58	69	140	125	M20X40	279	65	360	600	110	130	730	121	14	15	350	360	740	370	1020	1085	475	185	350
ASBG 180M												670			800							440	1090	1155			
ASBG 200S	200	70	20	62.5	74.5	140	125	M20X40	318	80	400	645	120	185	815	133	18	19	370	400	780	390	1090	1160	475	185	350
ASBG 200M												725			895							470	1170	1240			
ASBG 225S	225	80	22	71	85	170	140	M20X40	356	85	450	735	140	200	925	149	18	19	430	450	980	475	1290	1355	550	215	430
ASBG 225M												825			1015							565	1380	1445			
ASBG 250S	250	90	25	81	95	170	140	M24X50	406	95	500	785	150	240	1015	168	22	24	455	500	1030	530	1420	1490	530	215	430
ASBG 250M												885			1115							630	1520	1590			
ASBG 280S	280	95	25	86	100	170	140	M24X50	457	100	560	850	160	230	1100	190	22	24	485	560	1090	585	1500	1565	530	215	430
ASBG 280M												960			1210							695	1610	1675			

Note : For Nonstandard motor, refer to Works.



DC Motors

AUX MILL DUTY D.C. MOTORS TO AISE/IPSS STANDARDS

Crompton Greaves Ltd., a name synonymous with rotating machines backed by its long proven expertise in the field of DC motors offers the entire range of state of art Auxiliary Mill Duty 800 series DC motors in frames 802 to 818 from 7.5 kW at 900 RPM to 187 kW at 435 RPM to AISE/IPSS Standards.

These motors are very rugged, reliable and suitable for steel mills or like applications.

818, 816, 814, 812, 810, 808, 806, 804, 803 & 802 frames are manufactured at CGL, LT Motors Division, Ahmednagar (Lam yoke DC motor frames 100 to 280 are also manufactured here). M3 Division is accredited with **ISO 9001 Certification** by BVQI for Quality Management System.

SALIENT FEATURES

- Conforming to AISE technical report no. 1-1991 / IPSS 1-03-002-94.
- Full speed, half speed and quarter speed designs available.
- Suitable for operations upto 500 volts.
- Suitable for operation on 3 phase, 6 pulse thyristor converter.
- Class 'H' insulation with class 'F' temperature rise limits.
- Armature class 'H' with VPI in solventless polyesterimide resin.
- TIG welding of armature coil connection to commutator.
- Split / Non split yoke without compensating winding or non split laminated yoke with compensating winding. However split yoke is preferred for 808 & above frames and compensating type for 812 & above frames.
- Replaceable shaft.
- Double shaft extension 1:9.6 taper with key way parallel to taper as per AISE or 1:10 taper with key way parallel to shaft axis as per IPSS.
- Convertible between TENV & TEFV enclosure or with top mounted blower unit.
- Loose hanging leads or terminal box as required.
- Axial play of 3 mm approximately of shaft.
- Brush position of 45 deg. for easy access for maintenance (except in case of laminated yoke version).
- Motor mounting dimension can be matched to replace 600 series motors to AISE or Russian standard.

STANDARD DATA OF MILL DUTY FRAMES 802 TO 818 AS PER AISE TECH REPORT 1

FRAME	kW RATING FORCED VENTILATED CONTINUOUS TENV ONE HOUR	BASE SPEED (RPM) AT 230V			ADJUSTABLE SPEED	SAFE SPEED (MECH) RPM	ROTOR GD SQ KGM SQ	APPROX TOTAL WEIGHT KG
		SHUNT	COMP	SERIES				
802C	7.5	900	900	800	900 / 1800	3600	0.8	300
803	11	800	800	725	800 / 2000	3300	1.5	400
804	15	725	725	650	725 / 1800	3000	2.6	500
806	22	650	650	575	650 / 1950	2600	4.5	700
808	37	575	575	525	575 / 1725	2300	8	900
810	52	550	550	500	550 / 1650	2200	15	1200
812	75	515	515	475	515 / 1300	1900	23	1600
814	112	500	500	460	500 / 1250	1700	36	2200
816	150	480	480	450	480 / 1200	1600	56	3000
818	187	435	435	410	435 / 1100	1500	85	3700

Northern Region Sales Office :

New Delhi :

Vandana, 11, Tolstoy Marg, New Delhi - 110 001
Phones : (011) 30416300

Jalandhar :

416-417, 3rd Floor, Prestige Chambers,
GT Road, Jalandhar - 144 001
Phones : (0181) 3240990

Lucknow :

Saran Chambers II, 3rd Floor, 5 Park Road,
Lucknow - 226 001
Phones : (0522) 3018850

Jaipur :

Church Road, P. O. Box. No. 173, Jaipur-302 001
Phones : (0141) 3018800

Eastern Region Sales Office :

Kolkata :

50, Chowringhee Road, Kolkata - 700 071
Phones : (033) 22829681-85

Bhubaneshwar :

Janpath Tower, Third Floor,
Ashok Nagar, Unit II,
Bhubaneshwar - 751 009
Phones : (0674) 2531128

Western Region Sales Office :

Mumbai :

Kanjur Marg (E), Mumbai-400 042.
Phones : (022) 67558000

Ahmedabad :

909-916, Sakar II, Near Ellis Bridge Police Station,
Ahmedabad - 380 006
Phones : (079) 40012000

Pune :

Premium Point, 4th Floor, Opp. Modern High School,
Jangali Maharaj Road, Pune 5.
Phones : (020) 25534675-77

Indore :

103-B, Apollo Trade Centre, 2B, Rajgarh Kothi,
Mumbai-Agra Road, Indore - 452 001.
Phones : (0731) 2498269

Nagpur :

3, West High Court Road, Lal Bahadur Shastri Chowk,
Dharampeth, Nagpur - 440 010
Phones : (0712) 2531271

Southern Region Sales Office :

Chennai :

No.3-A, MGR Salai, Kodambakkam High Road,
Nungambakkam,
Chennai - 600 034.
Phones : (044) 42247500

Bangalore :

1st Floor, Janardhana Towers, 562/640,
Bannerghetta Road, Bilekahalli, Bangalore 560 076.
Phones : (080) 41391908

Cochin :

Cherupushpam Building, 5th Floor, 300-6
Shanmugham Road, Ernakulum, Cochin - 682 031.
Phones : (0484) 2370860

Secunderabad :

4th Floor, Minerva House, 94, Sarojini Devi Road,
Secunderabad - 500 003.
Phones : (040) 40002300

Regional Service Centres :

North : Vandana, 11, Tolstoy Marg, New Delhi-110 001. Phones: (011) 30416308.

East : 21, R.N.Mukherjee Road, Kolkata-700 001. Phones: (033) 22489160.

West : Kanjur Marg (E), Mumbai 400 042. Phones : (022) 67558590.

South : 3A, MGR Salai, Kodambakkam High Road, Nungambakkam, Chennai-600 034. Phones : (044) 23651369.

NOTE : As the design and manufacture of Crompton Greaves electrical equipment are subject to constant improvement, the product supplied may differ in some details from the specifications and illustrations given in this booklet. For more details, contact Works.

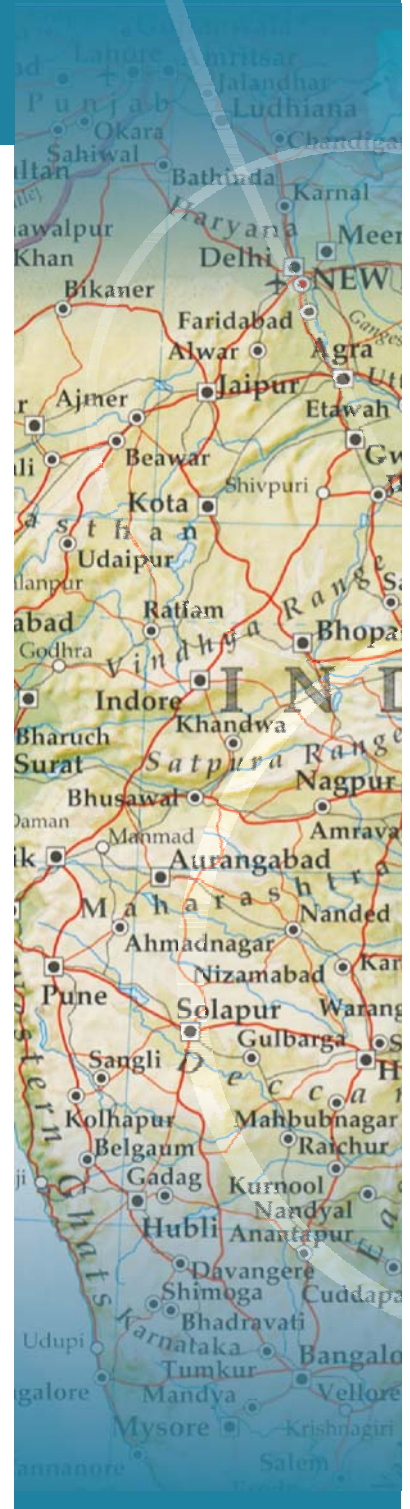

**Crompton
Greaves**

EVERYDAY SOLUTIONS

Regd Office : CG House, 6th Floor, Dr. Annie Besant Road, Worli, Mumbai - 400 025
Tel.: (022) 2423 7777. Fax : (022) 2438 2288

Manufacturing Units:

Goa Works :

D-2/21/22/23, Tivim Industrial Estate, Karaswada, Bardez, Goa - 403 526.
Tel.: (0832) 2257409, 2257639 Fax: (0832) 2257207

Ahmednagar Works:

A-6/2, M.I.D.C. Industrial Area, Ahmednagar - 414111
Tel.: (0241) 2776 150 - 157. Fax : (0241) 2777508